

# Solenoid Valves 112, 182 Series

By using the external pilot type valves, the 112, 182 series offers diverse functions of 2-, 3- port valves to achieve multiple functions and excellent performance in a compact body.

## ●112E1 and 182E1 for positive pressure applications

Ensures stable switching from low to high pressure (0~0.7MPa [0~102psi.]). Due to having no restrictions on connection port locations and flow direction, this series valve can be used as a 2-, 3-port valve for both the NC (normally closed) and NO (normally open) types, as well as for selector valves (dual-pressure switching valves) or divider valves.

## ●V112E1 and V182E1 for vacuum applications

As with positive pressure valves, this is a 2-, 3-port valve that puts no restrictions on connection port locations and flow direction, for both the NC (normally closed) and NO (normally open) types. Since this type can be used for both vacuum and positive pressure applications, it can serve as a vacuum breaking valve.

※Other vacuum valves are also available. For details, see p.852.

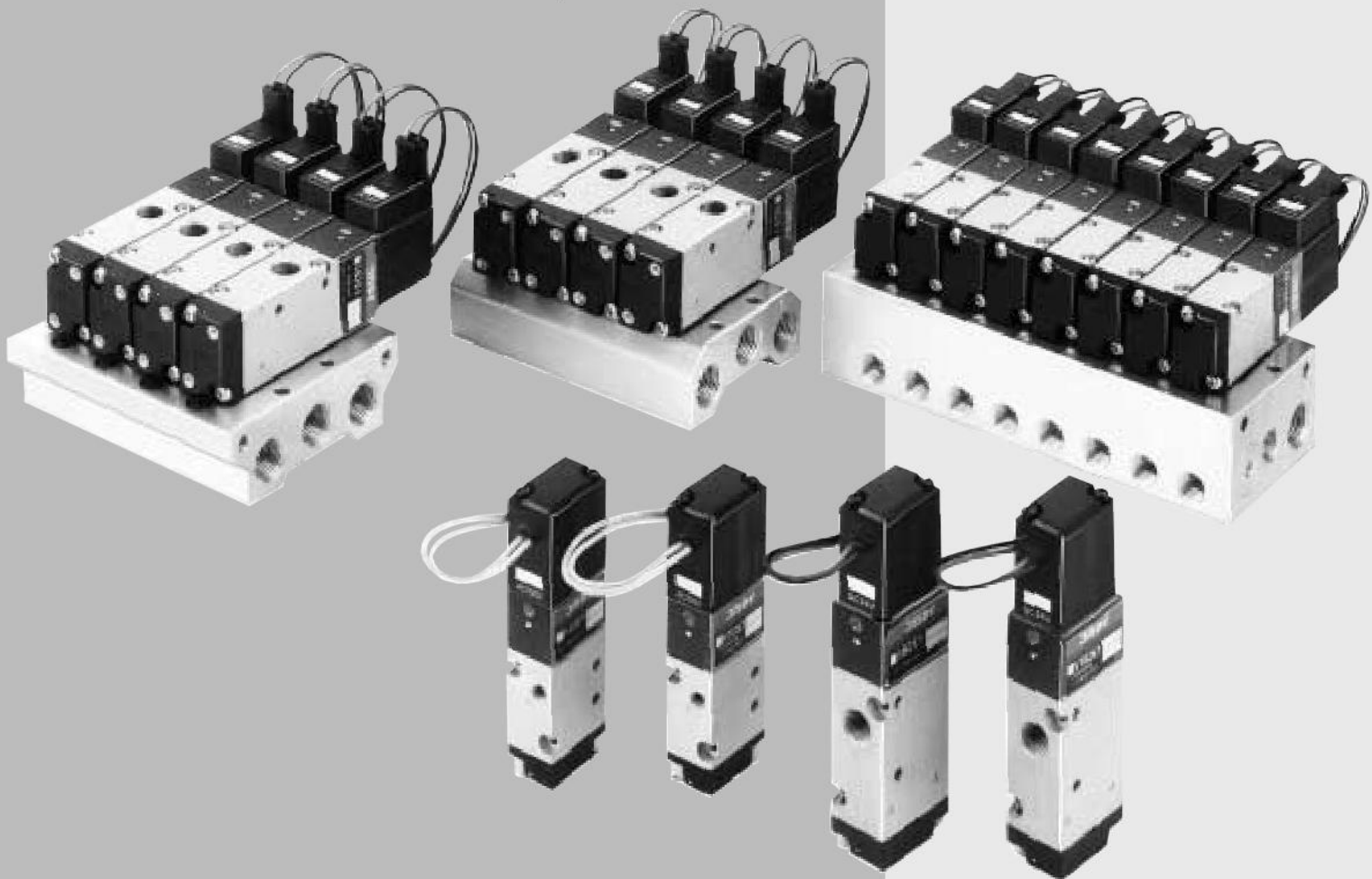
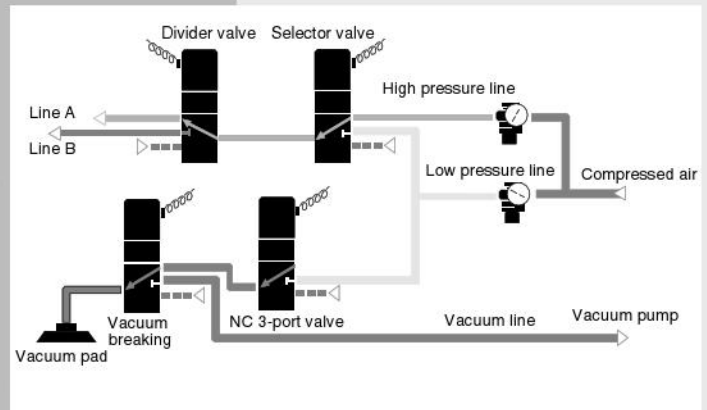

Single unit

112 series		182 series	
For positive pressure	For vacuum	For positive pressure	For vacuum
 <p><b>112E1</b></p>	 <p><b>V112E1</b></p>	 <p><b>182E1</b></p>	 <p><b>V182E1</b></p>

Manifold

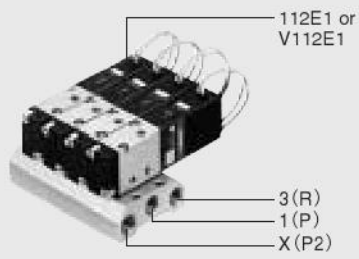
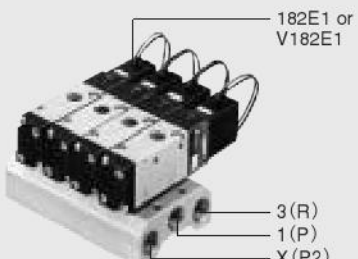
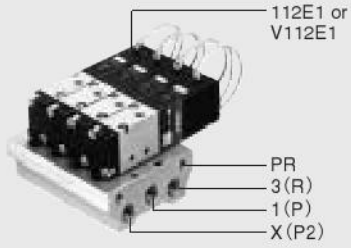
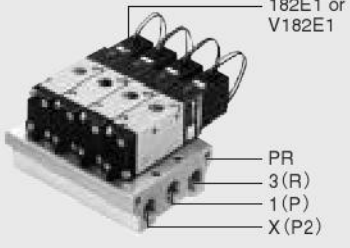
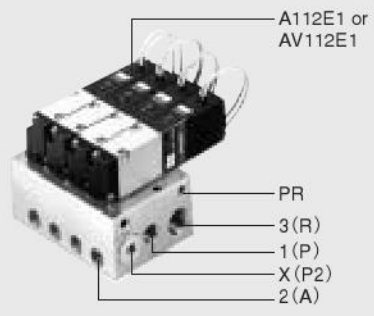
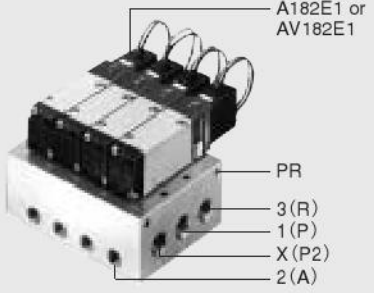
112M series	182M series
<p><b>112M□F—F type (1(P), 3(R), X(P2)) manifold</b></p>  <p>112E1 or V112E1</p> <p>3(R) 1(P) X(P2)</p>	<p><b>182M□F—F type (1(P), 3(R), X(P2)) manifold</b></p>  <p>182E1 or V182E1</p> <p>3(R) 1(P) X(P2)</p>
<p><b>112M□FE—FE type (1(P), 3(R), X(P2), PR) manifold</b></p>  <p>112E1 or V112E1</p> <p>PR 3(R) 1(P) X(P2)</p>	<p><b>182M□FE—FE type (1(P), 3(R), X(P2), PR) manifold</b></p>  <p>182E1 or V182E1</p> <p>PR 3(R) 1(P) X(P2)</p>
<p><b>112M□A—A type (all ports) manifold</b></p>  <p>A112E1 or AV112E1</p> <p>PR 3(R) 1(P) X(P2) 2(A)</p>	<p><b>182M□A—A type (all ports) manifold</b></p>  <p>A182E1 or AV182E1</p> <p>PR 3(R) 1(P) X(P2) 2(A)</p>



# 112, 182 Series Manifold Order Codes

**2-, 3-port valve**  
Number of ports

3-port  
  
Blank

2-port  
  
-2

**Manual override**

Non-locking type  
  
Blank

Locking protruding type  
  
-83

**Wiring type**

Grommet type  
  
Blank

Straight connector with LED indicator  
  
-PSL

L connector with LED indicator  
  
-PLL

● Lead wire length: 300mm [11.8in.] is standard.

Straight connector with LED indicator  
  
-CPSL  
-CMSL

L connector with LED indicator  
  
-CPLL  
-CMLL

● -CP□L: DC12V and DC24V positive side, and AC100V, AC200V.  
● -CM□L: DC12V and DC24V negative side.

Manifold model	Number of units	Station	Basic model				Voltage	
112M	2 ⋮ 20	F FE	stn.□	112E1	-2	-83	-PSL -PLL -CPSL -CMSL -CPLL -CMLL	DC12V DC24V AC100V AC200V
			stn.□	V112E1				
		A		A112E1				
				AV112E1				
182M	2 ⋮ 20	F FE	stn.□	182E1	-2	-83	-PSL -PLL -CPSL -CMSL -CPLL -CMLL	DC12V DC24V AC100V AC200V
			stn.□	V182E1				
		A		A182E1				
				AV182E1				

- Valve mounting location from the left-hand side when facing the 2(A) port.
- Specify the valve model for each station.
- Enter **-BP** when closing a station with a block-off plate without mounting a valve.
- Positive pressure and vacuum valves can be used on the same manifolds, but they cannot be mounted together.
- When ordering the non-ion specification, enter **-NCU** after the basic model code.
- Pre-wired common terminal for AC100V and AC200V is either **-CPSL** or **-CPLL**.

## Made to Order

The 112, 182 series includes made to order items for further system development. For details, see p.379.

Straight connector with LED indicator  
  
-PSLN

- Without lead wire
- Connector and contacts included

L connector with LED indicator  
  
-PLLN

- Without lead wire
- Connector and contacts included

Lead wire length  
  
-1L  
-3L

- For plug connector
- Length -1L: 1000 [39in.]
- -3L: 3000 [118in.]

DIN connector  
  
-39

- Cannot be used with -L.

LED indicator with built-in varistor  
  
-L

- Cannot be used with -39.

Built-in interface unit  
  
-FA

- Enables direct control by output from micro computer or other logic devices.
- With LED indicator

Sub-base regulator  
  
-52

- Only for 182 series
- Regulates the pressure at each station on the manifold.

# SOLENOID VALVES

## 112 SERIES

### Basic Models and Functions

Item	Basic model	For positive pressure		For vacuum	
		Direct piping, F, FE type manifolds	<b>112E1</b>	<b>V112E1</b>	A type manifold
Number of positions		2 positions			
Number of ports		2, 3 ports			
Valve function <sup>Note</sup>		Dual use for normally closed (NC) and normally open (NO) types			

Remark: For optional specifications and order codes, see p.367~368.  
Note: For details, see the handling instructions and precautions on p.381.

### Solenoid Specifications

Item	Rated voltage	DC12V	DC24V	AC100V	AC200V
Type		Flywheel diode incorporated for surge suppression		Shading type	
Operating voltage range	V	10.8~13.2 (12±10%)	21.6~26.4 (24±10%)	90~132 (100 <sup>+32</sup> / <sub>-10</sub> %)	180~264 (200 <sup>+32</sup> / <sub>-10</sub> %)
Current (when rated voltage is applied)	Frequency	Hz	—	50	60
	Starting	mA (r.m.s)	—	36	32
	Energizing	mA (r.m.s)	130 (1.6W) 140 (1.7W) [with LED indicator]	65 (1.6W) 75 (1.8W) [with LED indicator]	24
Allowable leakage current	mA	8	4	4	2
Insulation resistance	MΩ	Over 100			
Wiring type and lead wire length	Standard	Grommet type: 300mm [11.8in.]			
	Optional	Plug connector type: 300mm [11.8in.] See made to order on p.379.			
Color of lead wire		Brown (+) Black (-)	Red (+) Black (-)	Yellow	White
Color of LED indicator (optional)		Red		Yellow	Green
Surge suppression (as standard)		Flywheel diode		Varistor	

### Solenoid Valve Mass

g [oz.]

Basic model	Mass
<b>112E1</b>	80 [2.82]
<b>A112E1</b>	85 [3.00]
<b>V112E1</b>	80 [2.82]
<b>AV112E1</b>	85 [3.00]

### Manifold Mass

g [oz.]

Manifold model	Mass calculation of each unit (n=number of units)	Block-off plate
<b>112M□F</b>	(20×n)+30 [(0.71×n)+1.06]	6 [0.21]
<b>112M□FE</b>	(40×n)+50 [(1.41×n)+1.76]	11 [0.39]
<b>112M□A</b>	(60×n)+60 [(2.12×n)+2.12]	11 [0.39]

### Specifications

Item	Basic model	For positive pressure		For vacuum	
		Direct piping, F, FE type manifolds	<b>112E1</b>	<b>V112E1</b>	A type manifold
Media		Air			
Operation type		External pilot type			
Effective area [Cv]		mm <sup>2</sup>		4.2 [0.23]	
Port size <sup>Note 1</sup>	Main	M5×0.8			
	Pilot	M5×0.8			
Lubrication		Not required			
Operating pressure range MPa {kgf/cm <sup>2</sup> } [psi.]	Main	0~0.7 [0~7.1] [0~102]	-750mmHg [-29.53in.Hg]	~0.15 [1.5] [22]	
	Pilot	0.2~0.7 {2.0~7.1} [29~102]			
Proof pressure	MPa {kgf/cm <sup>2</sup> } [psi.]	1.05 [10.7] [152]			
Response time <sup>Note 2</sup>	ms	DC12V, DC24V	15/25 or below		
ON/OFF		AC100V, AC200V	15/15 or below		
Maximum operating frequency	Hz	5			
Operating temperature range (atmosphere and media)	°C [°F]	5~50 [41~122]			
Shock resistance	m/s <sup>2</sup> [G]	1373.0 [140.0] (Axial direction 294.2 [30.0])			
Mounting direction		Any			

Notes: 1. For details, see the manifold connection port size on p.370.  
2. Values when air pressure is 0.5MPa [5.1kgf/cm<sup>2</sup>] [73psi.].

### Flow Rate

112 series

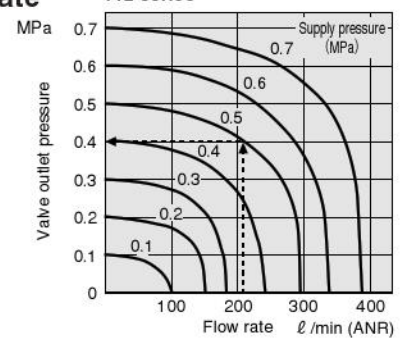

1MPa = 14.5psi., 1 l/min = 0.0353ft<sup>3</sup>/min.

#### How to read the graph

When the supply pressure is 0.5MPa [73psi.] and flow rate is 210 l/min [7.41ft<sup>3</sup>/min.] (ANR), the valve outlet pressure becomes 0.4MPa [58psi.].

## Manifold Connection Port Size

Manifold model	Port	Location of connection port	Port size
112M□F	1 (P)	Manifold	Rc1/8
	2 (A)	Valve	M5×0.8
	3 (R)	Manifold	Rc1/8
	X (P2)		
	PR	Valve	—
112M□FE	1 (P)	Manifold	Rc1/8
	2 (A)	Valve	M5×0.8
	3 (R)	Manifold	Rc1/8
	X (P2)		
	PR	Manifold	M5×0.8
112M□A	1 (P)	Manifold	Rc1/8
	2 (A)		Rc1/4
	3 (R)		M5×0.8
	X (P2)		
	PR		

## Operating Principles and Symbols

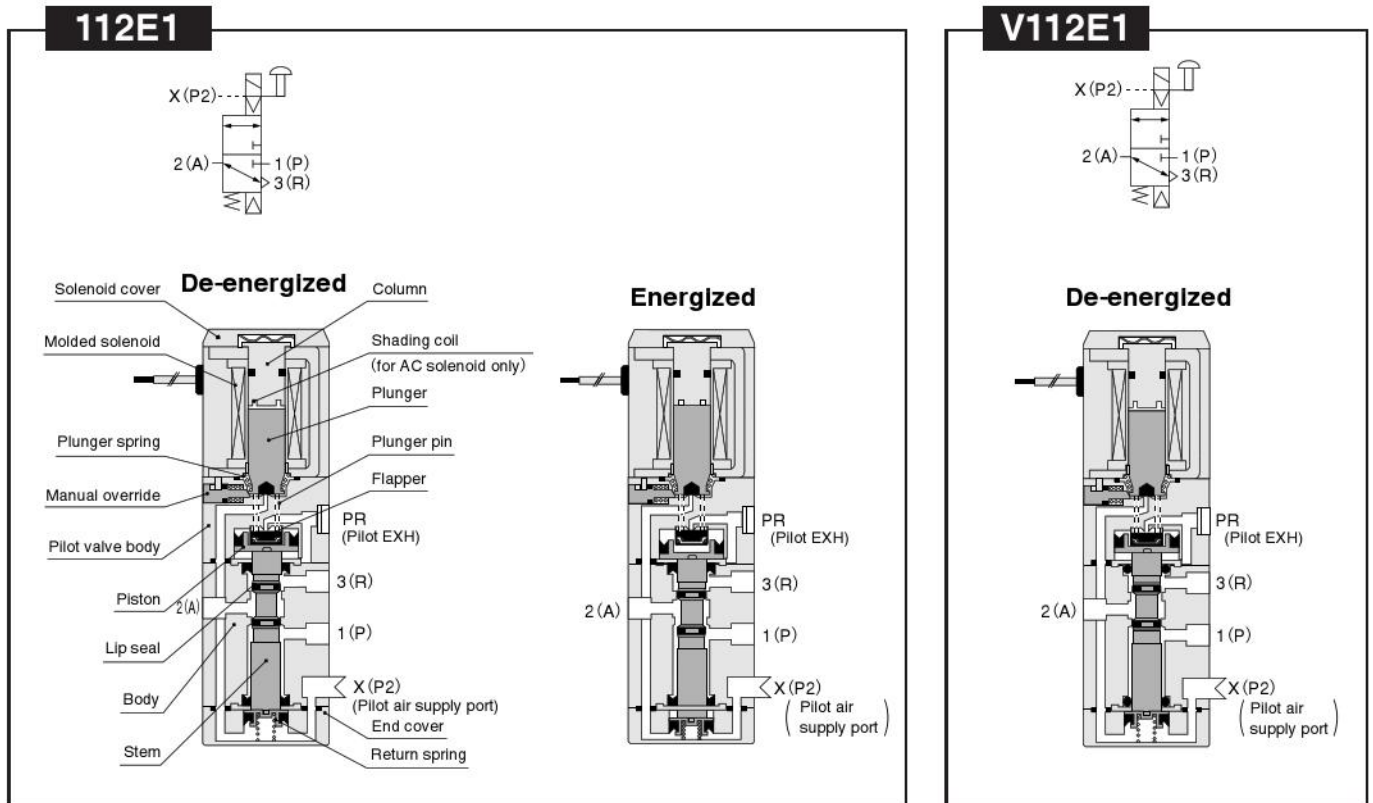

## Major Parts and Materials

Parts		Materials
Valve	Body	Aluminum alloy (anodized)
	Stem	
	Lip seal	Synthetic rubber
	Flapper	
	Mounting base	Mild steel (zinc plated)
	Sub-base	Aluminum alloy (anodized)
	Plunger	Magnetic stainless steel
Column		
Manifold	Body	Aluminum alloy (anodized)
	Block-off plate	Mild steel (nickel plated)
	Seal	Synthetic rubber

Remark: Materials that generate copper ions are not used for the non-ion specification.

# Dimensions of Solenoid Valve (mm)

**112E1**  
**V112E1**

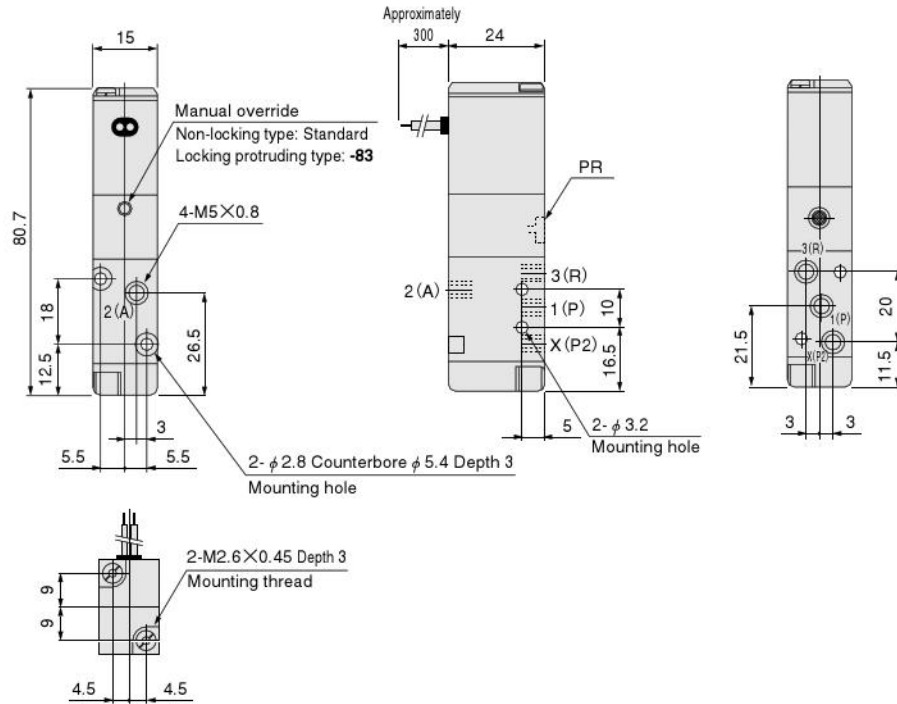

## Additional Parts (To be ordered separately)

- Mounting base: **110-21**

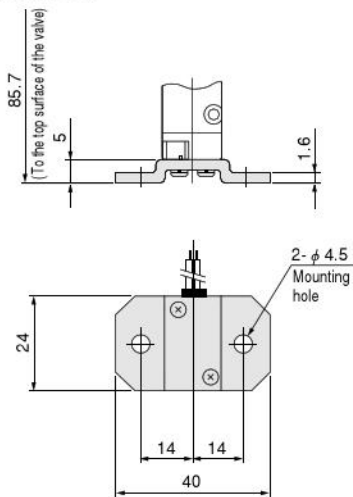

- Muffler: **KM-05**

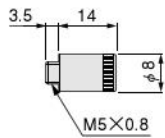

## Options

- Locking protruding type manual override: **-83**

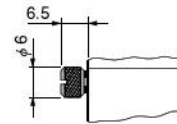

- Solenoid with straight connector: **-PSL**

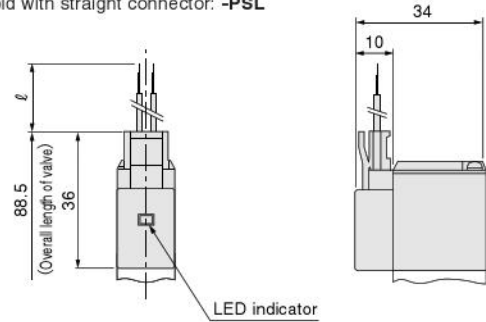

- Solenoid with L connector: **-PLL**

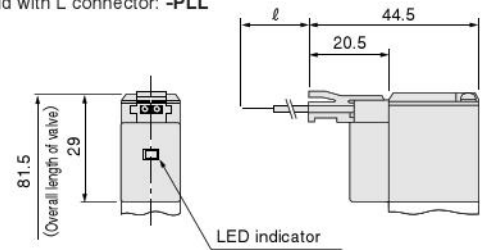

- Lead wire length  $\ell$  **-PSL, -PLL: 300**  
Made to order **-1L: 1000, -3L: 3000**

## Made to Order

- Solenoid with DIN connector: **-39**

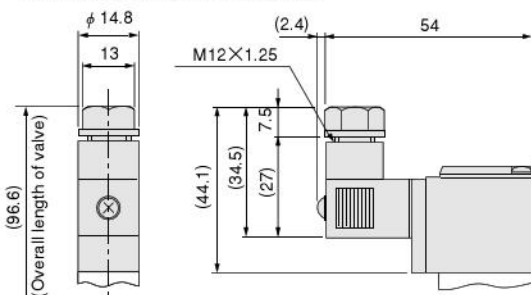

- Solenoid with LED indicator: **-L**

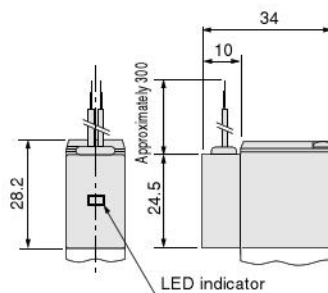

- Built-in interface unit: **-FA**

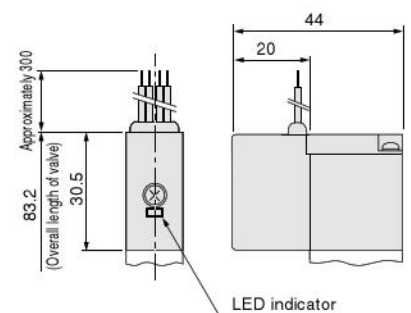

# Dimensions of Manifold (mm)

## 112M□F

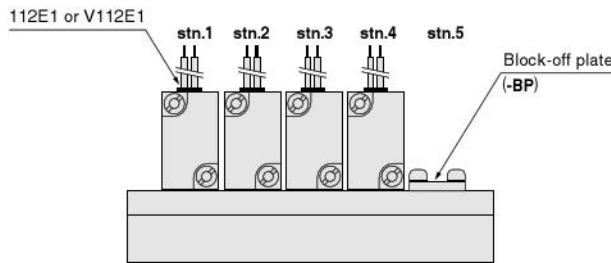
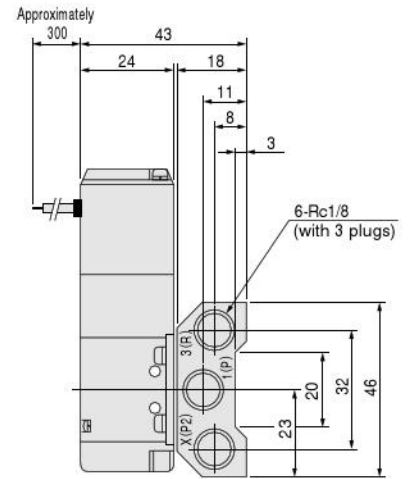
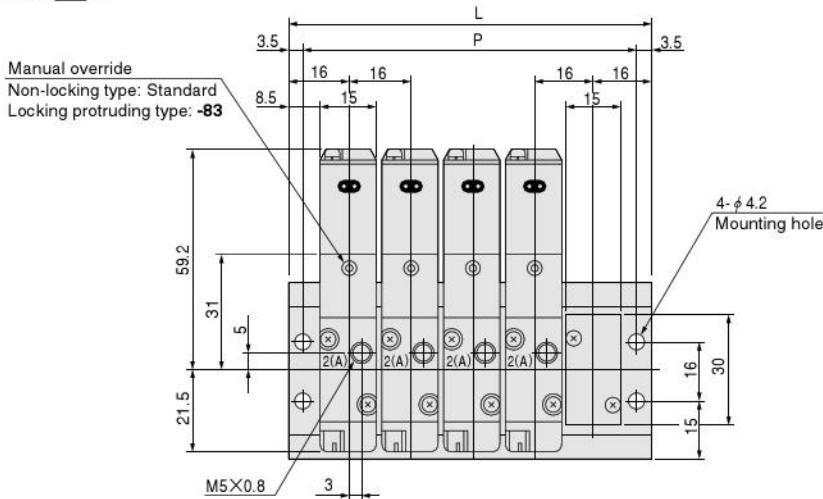

### Unit dimensions

Model	L	P	Model	L	P
112M2F	48	41	12F	208	201
3F	64	57	13F	224	217
4F	80	73	14F	240	233
5F	96	89	15F	256	249
6F	112	105	16F	272	265
7F	128	121	17F	288	281
8F	144	137	18F	304	297
9F	160	153	19F	320	313
10F	176	169	20F	336	329
11F	192	185			

## 112M□FE

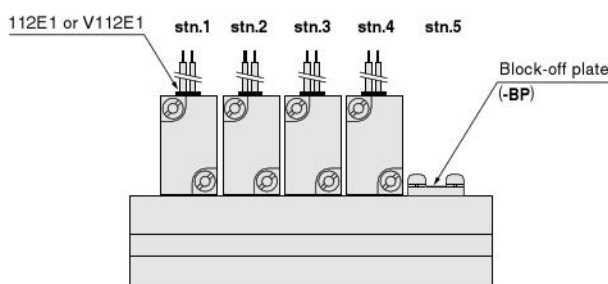
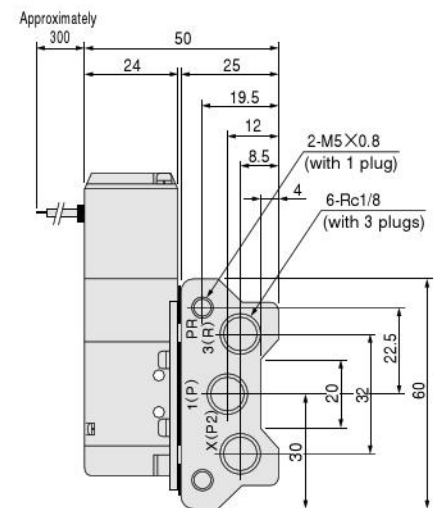
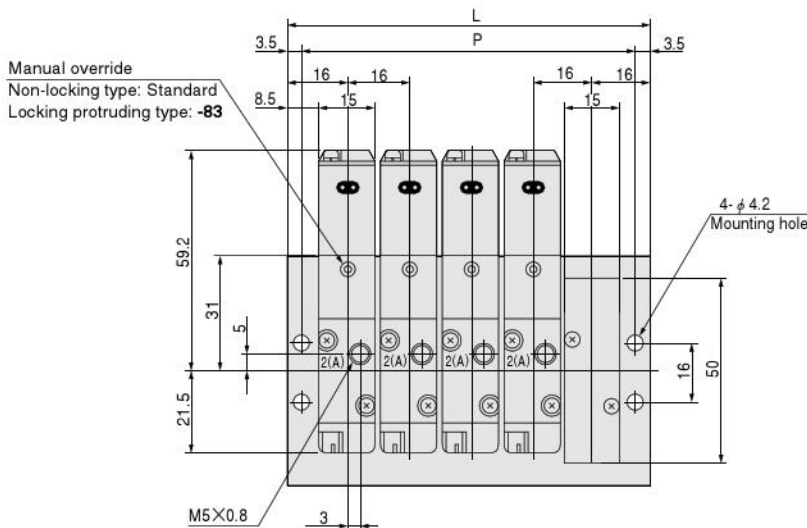

### Unit dimensions

Model	L	P	Model	L	P
112M2FE	48	41	12FE	208	201
3FE	64	57	13FE	224	217
4FE	80	73	14FE	240	233
5FE	96	89	15FE	256	249
6FE	112	105	16FE	272	265
7FE	128	121	17FE	288	281
8FE	144	137	18FE	304	297
9FE	160	153	19FE	320	313
10FE	176	169	20FE	336	329
11FE	192	185			

# Dimensions of Manifold (mm)

## 112M□A

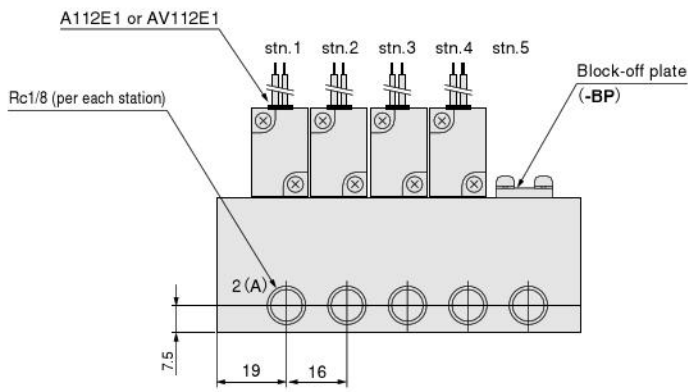
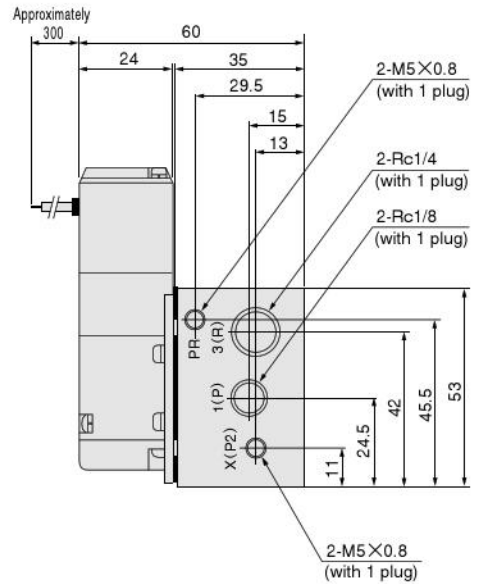
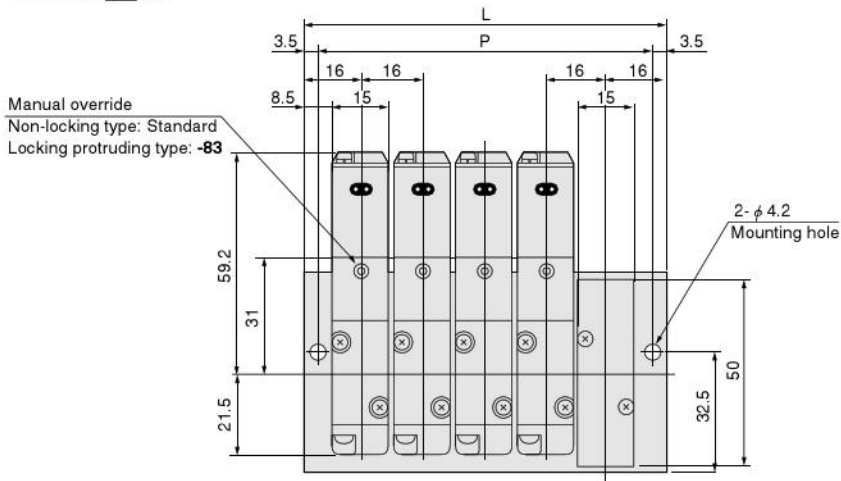

### Unit dimensions

Model	L	P	Model	L	P
112M2A	48	41	12A	208	201
3A	64	57	13A	224	217
4A	80	73	14A	240	233
5A	96	89	15A	256	249
6A	112	105	16A	272	265
7A	128	121	17A	288	281
8A	144	137	18A	304	297
9A	160	153	19A	320	313
10A	176	169	20A	336	329
11A	192	185			

## Options

- Locking protruding type manual override: -83
- Solenoid with straight connector: -PSL
- Solenoid with L connector: -PLL

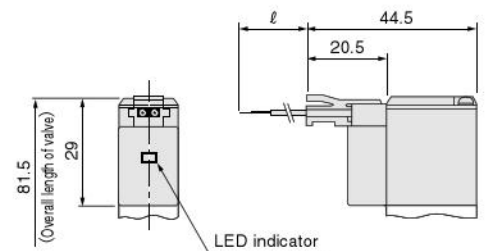
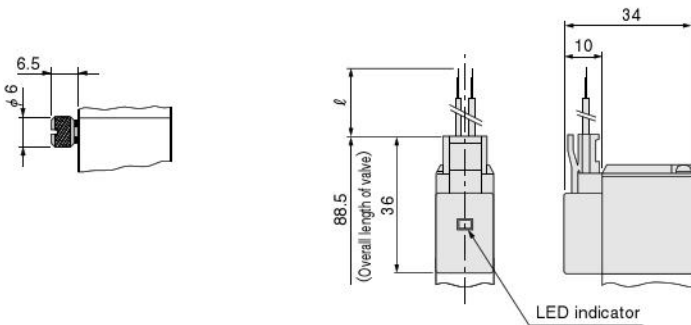

- Lead wire length  $l$  -PSL, -PLL: 300  
Made to order -1L: 1000, -3L: 3000

## Made to Order

- Solenoid with DIN connector: -39
- Solenoid with LED indicator: -L
- Built-in interface unit: -FA

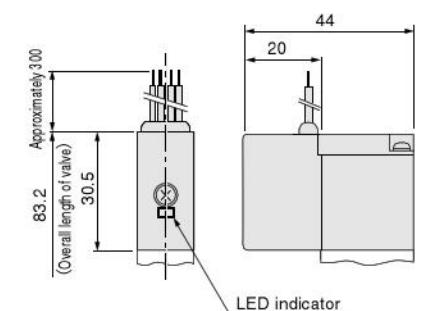
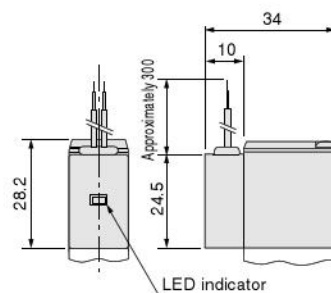
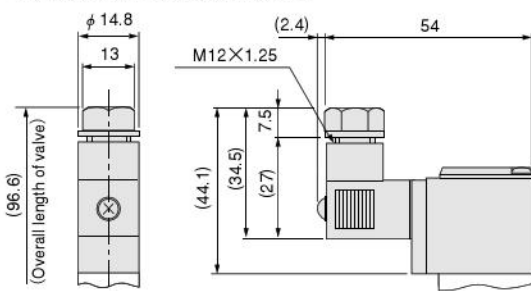

## Made to Order

In the 112, 182 series solenoid valves, various types of made to order items are available.

### Plug connector

Straight connector  
with LED indicator



- Without lead wire
- Connector and contacts included

L connector  
with LED indicator



- Without lead wire
- Connector and contacts included

- When ordering, enter **-PSLN** or **-PLLN** in place of the normal option code for the wiring type.

Lead wire length

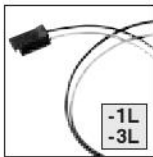

- For plug connector
- Length **-1L** : 1000 (mm)
- **-3L** : 3000

- For lead wire length, **-1L** is 1000mm [39in.] and **-3L** is 3000mm [118in.].
- When ordering, enter **-1L** or **-3L** following the wiring type option code.

### DIN connector



A compact connector that is highly resistant to dust and water splashes.

Employs a self-stripping method that eliminates the need for de-sheathing the lead wire.

- When ordering, enter **-39** in place of the normal option code for the wiring type.
- A varistor for surge suppression equipped as standard. (For the AC100V and AC200V only. For the DC12V and DC24V, a flywheel diode for surge suppression is installed as standard equipment.)
- LED indicator is not available.

### Built-In Interface unit



Includes an interface unit with photo transistor. Can be directly controlled by a microcomputer and logic devices, and is equipped with fully electric noise countermeasures and LED indicators.

- When ordering, enter **-FA** in place of the normal option code for the wiring type.
- Cannot be ordered in combination with any other solenoid option.
- Solenoid voltages are AC100V and AC200V only.

### LED Indicator

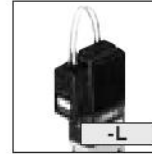

The LED indicator for confirmation of operation is also available without a plug connector. This creates a clean monoblock look with the compact cover.

- When ordering, enter **-L** in place of the normal option code for the wiring type.
- A varistor for surge suppression equipped as standard. (For the AC100V and AC200V only. For the DC12V and DC24V, a flywheel diode for surge suppression is installed as standard equipment.)

### Sub-base regulator

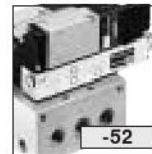

- Only for 182 series

### Specifications

Item	Order code	<b>-52(180MA-52)</b> <sup>Note</sup>
Function		1(P) port pressure regulating type
Media		Air
Operating pressure range MPa {kgf/cm <sup>2</sup> } [psi.]		0.15~0.5 {1.5~5.1} [22~73]
Maximum operating pressure MPa {kgf/cm <sup>2</sup> } [psi.]		0.7 {7.1} [102]
Proof pressure MPa {kgf/cm <sup>2</sup> } [psi.]		1.05 {10.7} [152]
Operating temperature range °C [°F]		5~50 [41~122]
Mass	g [oz.]	80 [2.82]

Note: The order code in parentheses ( ) is for the sub-base regulator only.

※For made to order details, see the solenoid valves 180 series on p.353~356.

# Handling Instructions and Precautions



## Solenoid

### Internal circuit

#### ● DC12V, DC24V

#### Standard solenoid (Surge suppression)

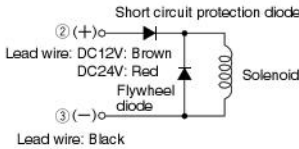

② and ③ are for with DIN connector (Order code: -39).

#### Solenoid with LED indicator (Surge suppression) Order code: -PSL, -PLL

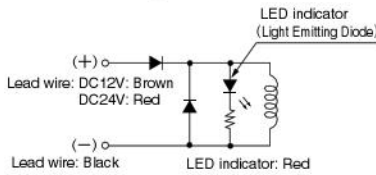

#### ● AC100V, AC200V

#### Standard solenoid (Surge suppression)

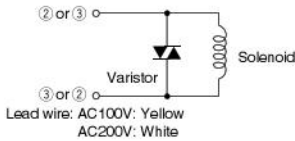

② and ③ are for with DIN connector (Order code: -39).

#### Solenoid with LED indicator (Surge suppression) Order code: -PSL, -PLL

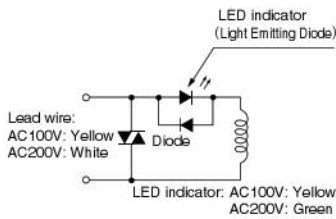

- Cautions:**
1. Do not apply megger between the lead wires.
  2. The DC solenoid will not short circuit even if the wrong polarity is applied, but the valve will not operate.
  3. Leakage current inside the circuit could result in failure of the solenoid valve to return or in other erratic operation. Always use it within the range of the allowable leakage current. If circuit conditions, etc. cause the leakage current to exceed the allowable leakage current, consult us.



## Plug connector

### Attaching and removing plug connector

Use fingers to insert the connector into the pin, push it in until the lever claw latches onto the protruded section of the connector housing, and complete the connection. To remove the connector, squeeze the lever along with the connector, lift the lever claw up from the protruded section of the connector housing, and pull it out.

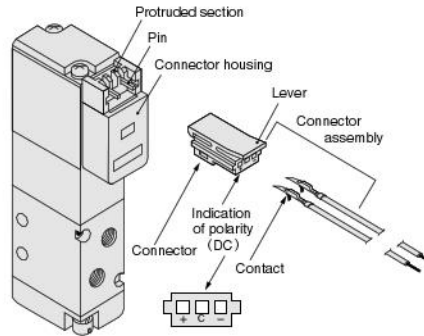

※ Illustration shows the 110 series.

### Crimping of connecting lead wire and contact

To crimp lead wires into contacts, strip off 4mm [0.16in.] of the insulation from the end of the lead wire, insert it into the contact, and crimp it. Be sure to avoid catching the insulation on the exposed wire crimping section.

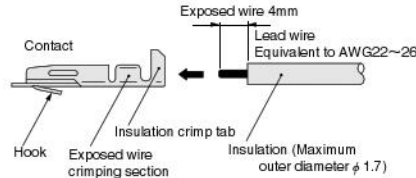

- Cautions:**
1. Do not pull hard on the lead wire.
  2. Always use a dedicated tool for crimping of connecting lead wire and contact.  
Contact: Model 702062-2M  
Manufactured by Sumiko Tech, Inc.  
Crimping tool: Model F1-702062  
Manufactured by Sumiko Tech, Inc.

### Attaching and removing contact and connector

Insert the contact with a lead wire into a plug connector □ hole until the contact hook latches on and is secured to the plug connector. Confirm that the lead wire cannot be easily pulled out.

To remove it, insert a tool with a fine tip (such as a small screwdriver) into the rectangular hole on the side of the plug connector to push up on the hook, and then pull out the lead wire.

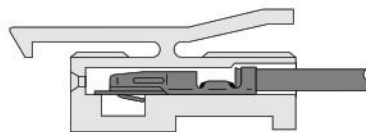

- Cautions:**
1. Do not pull hard on the lead wire. It could result in defective contacts, breaking wires, etc.
  2. If the pin is bent, use a small screwdriver, etc. to gently straighten out the pin, and then complete the connection to the plug connector.

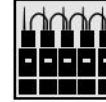

## Common terminal pre-wired plug connector

### 1. Pre-wired common terminal at DC positive side or AC

Order code With straight connector: -CPSL  
With L connector: -CPLL

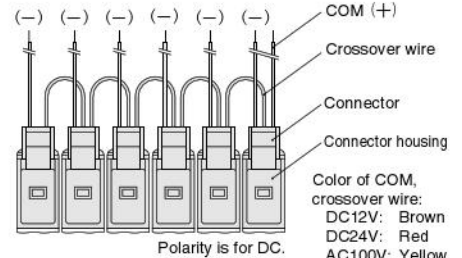

### 2. Pre-wired common terminal at DC negative side

Order code With straight connector: -CMSL  
With L connector: -CMLL

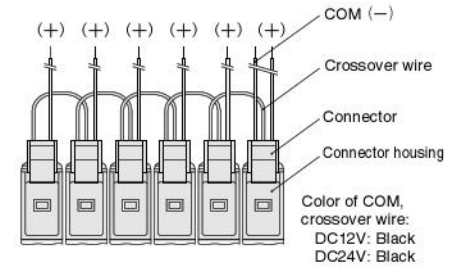

- Cautions:**
1. The diagrams show the straight connector configuration. While the connector's orientation is different in the case of the L connector, in every case the first COM lead wire comes from the last station's mounted valve.
  2. Since the COM terminal is connected to a crossover terminal inside the connector housing, the connector cannot be switched between a positive common and a negative common by changing the connectors.



## Manual override

### Non-locking type

To operate the manual override, press it all the way down. The valve works the same as when in the energized state as long as the manual override is pushed down, and returns to the normal position upon release.

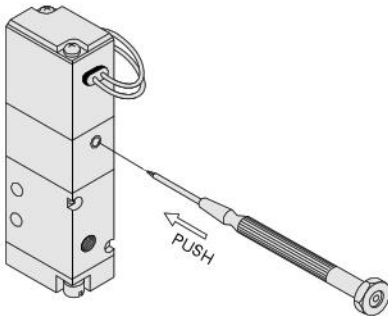

※ Illustration shows the 110 series.

### Locking protruding type

Use a small screwdriver to turn the adjusting knob several times in the clockwise direction, and lock the manual override in place. When locked, turning the adjusting knob several times in the counterclockwise direction releases a spring on the manual override, returns it to the normal position, and releases the lock.

For the locking protruding type, when the adjusting knob is not turned, this type acts just like the non-locking type; the valve enters the energized position as long as the manual override is pushed down, and returns to the normal position upon release.

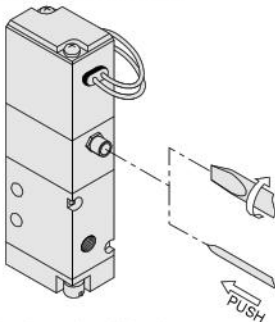

※ Illustration shows the 110 series.

- Cautions:**
1. The 112 and 118 series valves are pilot type solenoid valves. As a result, the manual override cannot switch the main valve without air supplied from the X(P2) port.
  2. Always release the lock of the locking type and locking protruding type manual override before commencing normal operation.
  3. Do not attempt to operate the manual override with a pin or other object having an extremely fine tip. It could damage the manual override button.
  4. Do not turn the adjusting knob more than needed. It could result in defective operation.



## External pilot

### Piping

1. Since the 112 and 182 Series valves are external pilot type solenoid valves, always supply pilot air (pressure 0.2~0.7MPa [29~102psi.]) to the X(P2) port.
2. Because there is no restriction of flow direction on piping to the main port (1(P), 2(A), and 3(R) ports), a single valve can be used for multiple functions. The air path between the 1(P) and 2(A) ports is normally closed (NC), while the air path between the 2(A) and 3(R) ports is normally open (NO). For the actual piping, see the piping examples in the diagram below:

### Valve functions and connection port locations

#### ● For positive pressure 112E1 and 182E1

	De-energized	Energized
2-port	Normally closed (NC) 2(A) ← 3(R) (Plug) 1(P)	←
	Normally open (NO) 2(A) ← 3(R) 1(P) (Plug)	←
3-port	Normally closed (NC) 2(A) ← 3(R) 1(P)	←
	Normally open (NO) 2(A) ← 3(R) 1(P)	←
Selector valve	2(A) ← 3(R) 1(P)	←
Divider valve	2(A) ← 3(R) 1(P)	←

#### ● For vacuum V112E1 and V182E1

	De-energized	Energized
2-port	Normally closed (NC) 2(A) ← 3(R) (Plug) 1(P) (vacuum / pad. etc.)	←
	Normally open (NO) 2(A) ← 3(R) 1(P) (Plug) (vacuum / pad. etc.)	←
3-port	Normally closed (NC) 2(A) ← 3(R) 1(P) (vacuum / pad. etc.)	←
	Normally open (NO) 2(A) ← 3(R) 1(P) (vacuum / pad. etc.)	←
Vacuum breaking	Normally closed (NC) 2(A) ← 3(R) 1(P) (vacuum / pad. etc.)	←
	Normally open (NO) 2(A) ← 3(R) 1(P) (vacuum / pad. etc.)	←

- Cautions:**
1. The valve inner construction differs between the positive pressure (112 and 182E1) and vacuum (V112E1 and V182E1) types. While the vacuum valve is capable of combining low positive pressure and vacuum piping, positive pressure valves cannot be used under vacuum.
  2. When positive pressure is applied to a vacuum valve for vacuum breaking, etc., the air pressure should be at 0.15MPa [22psi.] or less. For higher pressure applications, consult us.
  3. Always supply 0.2~0.7MPa [29~102psi.] of pilot air to the X(P2) port. The valve will not activate without pilot air.

### Mounting base 110-21,180-21

When installing a mounting base to the valve, always use the provided screws. The recommended tightening torque for the screws is 49N·cm {5kgf·cm} [4.3in·lbf].

### Mounting valves on manifold

When mounting valves on manifold, apply the following recommended tightening torque for the valve mounting screws.

112 series: 39.2N·cm {4kgf·cm} [3.5in·lbf]

182 series: 49N·cm {5kgf·cm} [4.3in·lbf]