

SOLENOID VALVES 025 SERIES

The 025 series power consumption is just 0.5W, also uses surge suppression, and enables direct drive by IC chips.



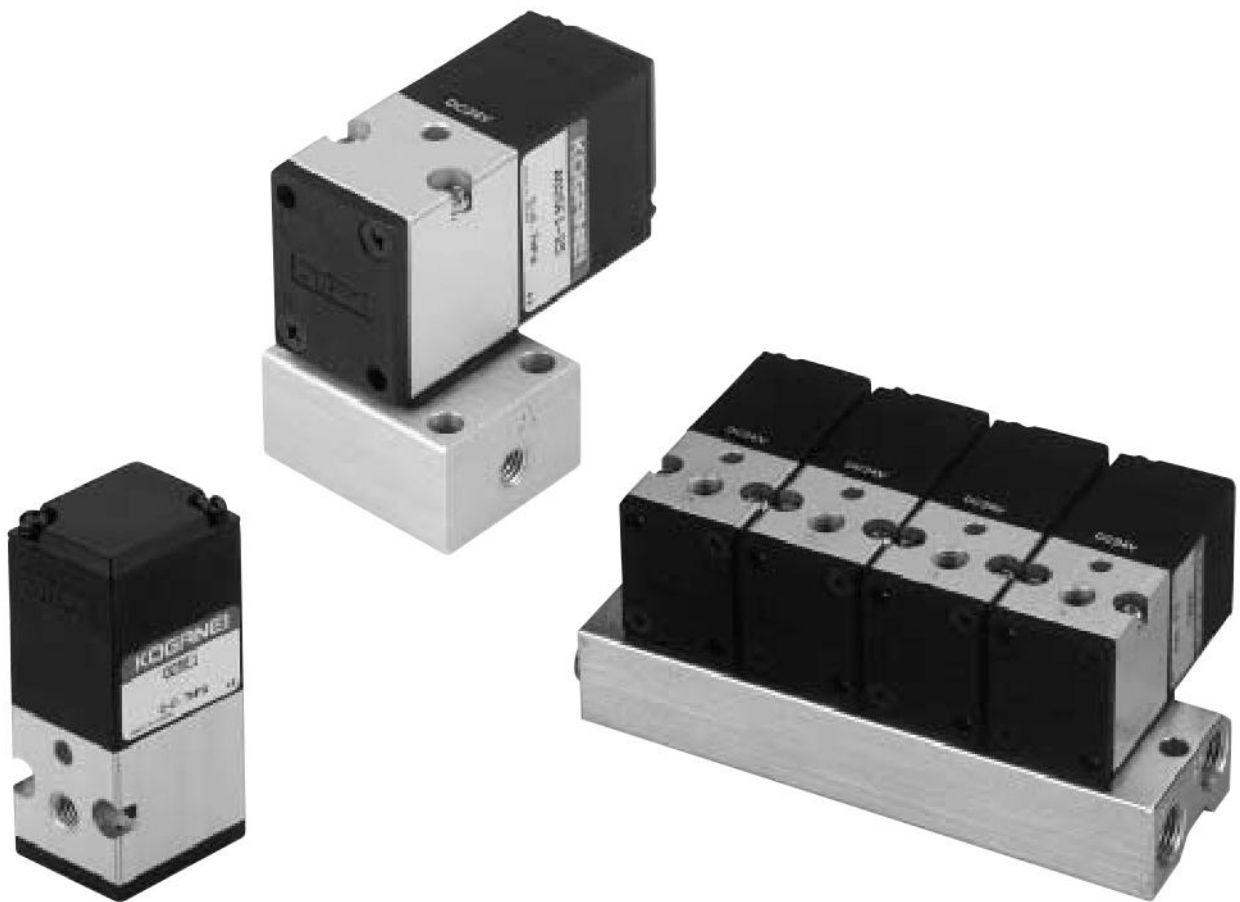

The control contactors and wiring housing, etc., have been made as compact as possible. Moreover, extremely low levels of heat and electric noise eliminate the need for countermeasures. As a result, the series contributes to compactness and energy savings for whole systems.

These simple, direct acting solenoid valves are highly reliable, and especially suitable as pilots for large valves.



They are also used for direct operation of compact actuators, for control of air bearings and other precision units, and for applications in many other fields.



Single unit

Direct acting solenoid valve			
Direct piping, F type manifold		Sub-base piping, A type manifold	
2-, 3-port		2-, 3-port	
Normally closed (NC)	Normally open (NO)	Normally closed (NC)	Normally open (NO)
			
025E1	025E1-11	A025E1-25	A025E1-11-25

Manifold

F type (P, R) manifold	A type (P, A) manifold
	
025M□F	025M□A

SOLENOID VALVES

025 SERIES

Specifications

Item	Basic model	
	Direct piping, F type manifold	Sub-base piping, A type manifold
	025E1	A025E1
Media	Air	
Operation type	Direct acting type	
Number of solenoids	Single solenoid	
Number of positions	2 positions	
Number of ports	2, 3 ports	
Effective area [Cv]	mm ²	0.5 [0.028] 0.4 [0.022]
Port size	M5×0.8	
Lubrication	Not required	
Operating pressure range	MPa [kgf/cm ²] [psi]	0~0.7 (0~7.1) [0~102]
Proof pressure	MPa [kgf/cm ²] [psi]	1.05 [10.7] [152]
Operating temperature range (atmosphere and media)	°C [°F]	5~50 [41~122]
Shock resistance	m/s ² [G]	78.5 [8.0]
Mounting direction	Any	
Mass	g [oz.]	80 [2.82] 80 [2.82] (110 [3.88]) ^{Note}

Note : The mass of A025E1 includes a sub-base.

Solenoid Specifications

Item	Rated voltage			
	DC5V	DC12V	DC24V	
Type	Flywheel diode incorporated for surge suppression			
Operating voltage range	V	4.5~5.5 (5±10%)	10.8~13.2 (12±10%)	21.6~26.4 (24±10%)
Power consumption	W	0.45	0.53	0.50
	Standard solenoid			
Current (when rated voltage is applied)	mA	90	44	21
	Standard solenoid			
Maximum allowable leakage current	mA	10	3	1.5
Insulation resistance	MΩ	Over 100		
	Standard	Grommet type: 300mm [11.8in.]		
Wiring type and lead wire length	Optional	Plug connector type Straight connector -PSL : 300mm [11.8in.] ^{Note 1} L connector -PLL : 300mm [11.8in.] ^{Note 1}		
	Standard	Grommet type: 300mm [11.8in.]		
Color of lead wire		Green (+), Black (-)	Brown (+), Black (-)	Red (+), Black (-)
Color of LED indicator ^{Note2}		Red		

Note1: 1000 [39in.] and 3000mm [118in.] are also available as options. Place separate orders as -1L : 1000mm [39in.], -3L: 3000mm [118in.] when placing an order.

2: The LED indicator is for the plug connector type solenoid only.

Flow Rate

025E1

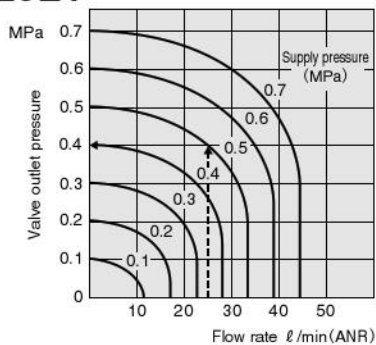

How to read the graph

When the supply pressure is 0.5MPa [73psi.] and flow rate is 25 l/min [0.88ft³/min.] (ANR), the valve outlet pressure becomes 0.4MPa [58psi.].

A025E1-25

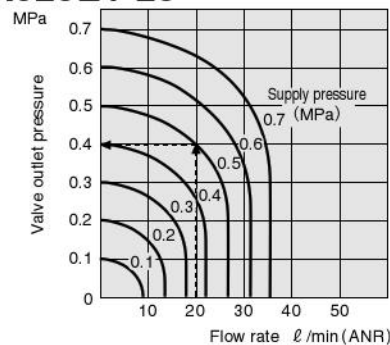

1MPa = 145psi., 1 l/min = 0.0353ft³/min.

How to read the graph

When the supply pressure is 0.5MPa [73psi.] and flow rate is 20 l/min [0.71ft³/min.] (ANR), the valve outlet pressure becomes 0.4MPa [58psi.].

● 025E1

Normally closed (NC)

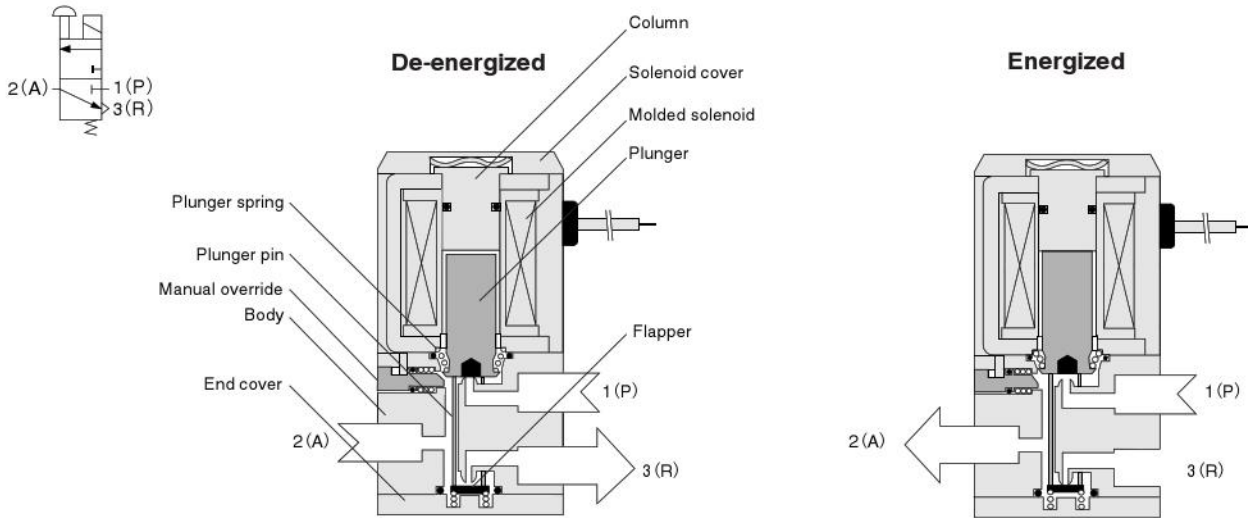

● 025E1-11

Normally open (NO)

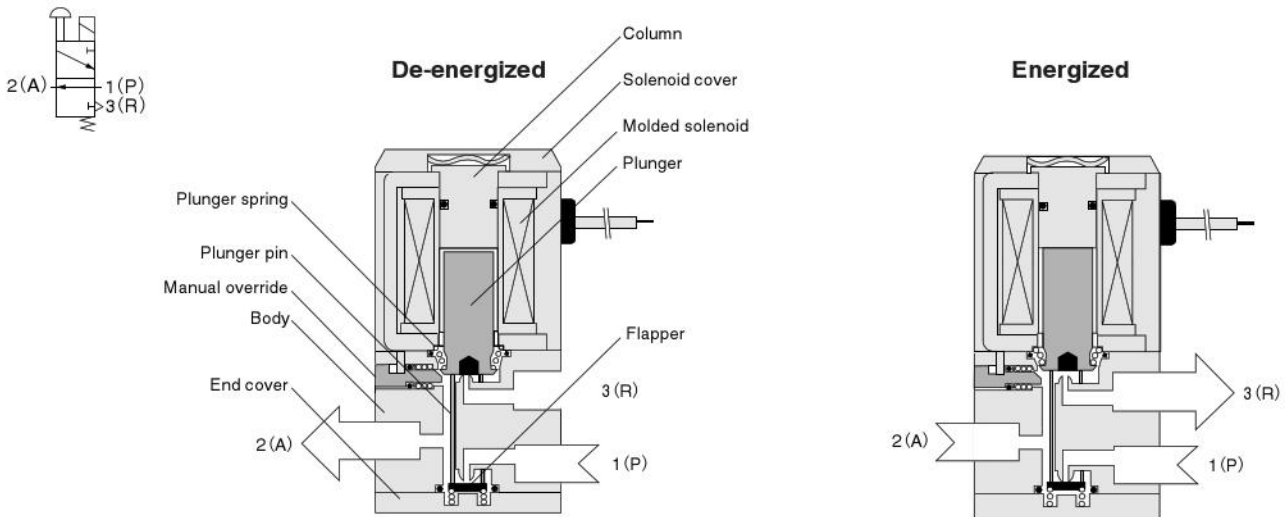

Major Parts and Materials

	Parts	Materials
Valve	Body	Aluminum alloy (anodized)
	Flapper	Synthetic rubber
	Plunger	Magnetic stainless steel
	Column	Magnetic stainless steel
	Mounting base	Mild steel (zinc plated)
	Sub-base	Aluminum alloy (anodized)
	Body	Aluminum alloy (anodized)
Manifold	Block-off plate	Mild steel (nickel plated)
	Seal	Synthetic rubber

Manifold Port Size

Manifold model		Port		
		1(P)	2(A)	3(R)
025M□F	Port location	Manifold	Valve	Manifold
	Port size	Rc1/8	M5×0.8	Rc1/8
025M□A	Port location	Manifold		
	Port size	Rc1/8	M5×0.8	Rc1/8

Mass

g [oz.]

Manifold model	Mass calculation of each unit (n=number of units)	Mounting valve		Block-off plate
		025E1	A025E1	
025M□F	$(26 \times n) + 10$ [(0.92×n)+0.35]	80 [2.82]	—	13 [0.46]
025M□A	$(31 \times n) + 22$ [(1.09×n)+0.78]	—	80 [2.82]	

025 Series Solenoid Valve Order Codes

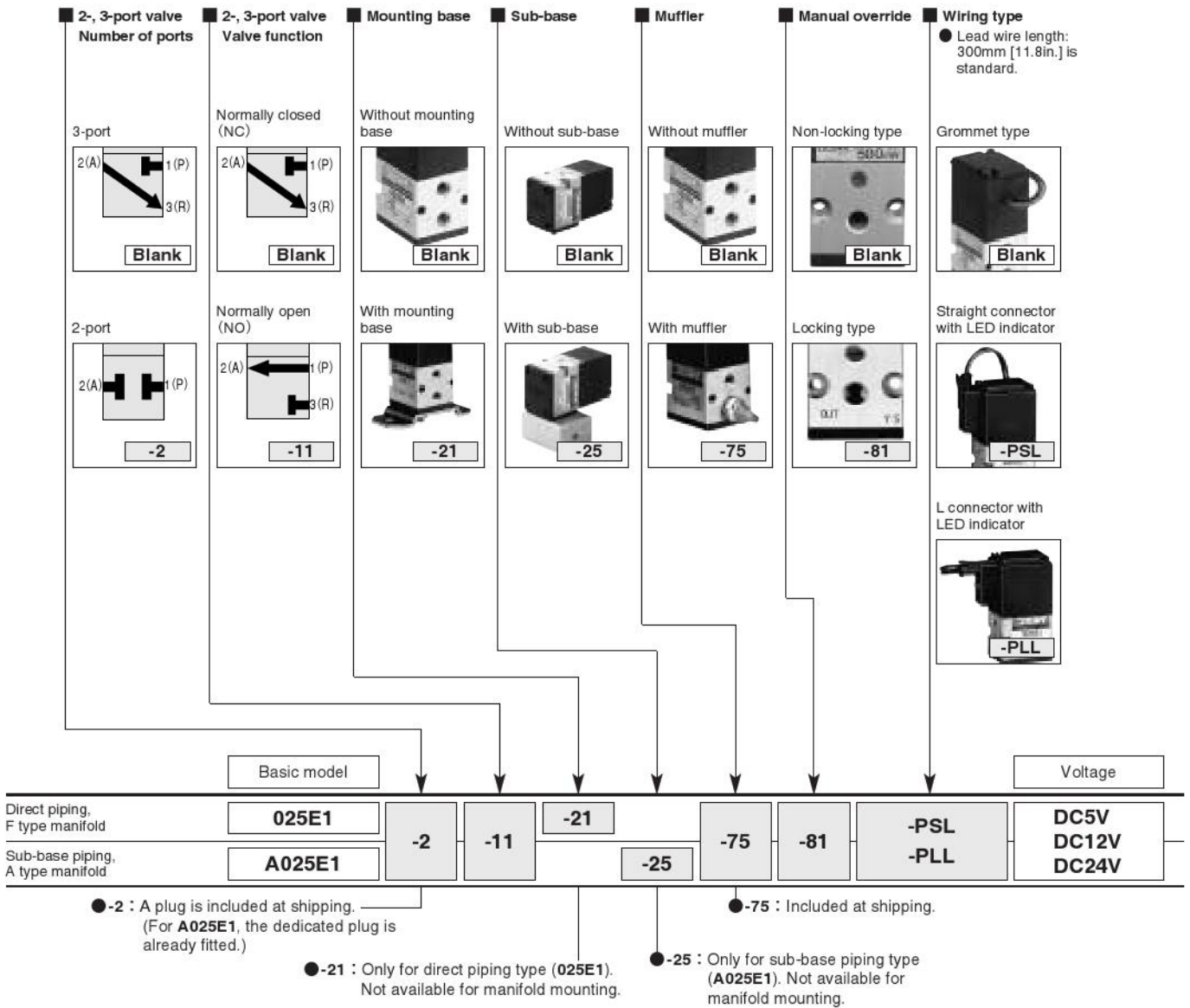

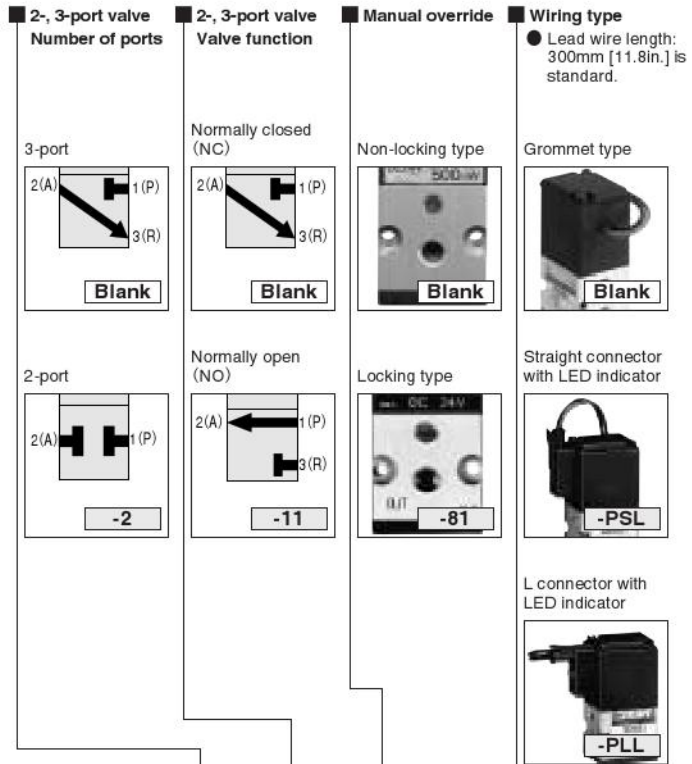



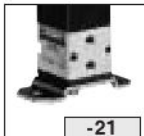

	Manifold model Number of units	Station	Basic model					Voltage		
F type (P,R) manifold	025M	2 ⋮ 10	F	stn. □	-025E1	-2	-11	-81	-PSL	DC5V DC12V DC24V
A type (P,A) manifold			A	stn. □	-A025E1				-PLL	

- Valve mounting location from the left-hand side when facing 2(A) port (□ : 1~10)
- Specify the valve type for each station.
- Enter **-BP** when closing a station with a block-off plate without mounting a valve.

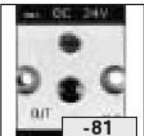
Options

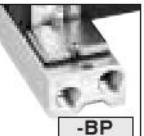
<p>Mounting base</p>  <p>-21</p> <p>● For direct piping</p>	<p>Sub-base</p>  <p>-25</p> <p>● For sub-base piping</p>	<p>Muffler</p>  <p>-75</p>	<p>Locking type manual override</p>  <p>-81</p>	<p>Straight connector with LED indicator</p>  <p>-PSL</p>	<p>L connector with LED indicator</p>  <p>-PLL</p>	<p>Block-off plate</p>  <p>-BP</p>
--	---	---	--	--	---	---

Dimensions of Solenoid Valve (mm)

025E1

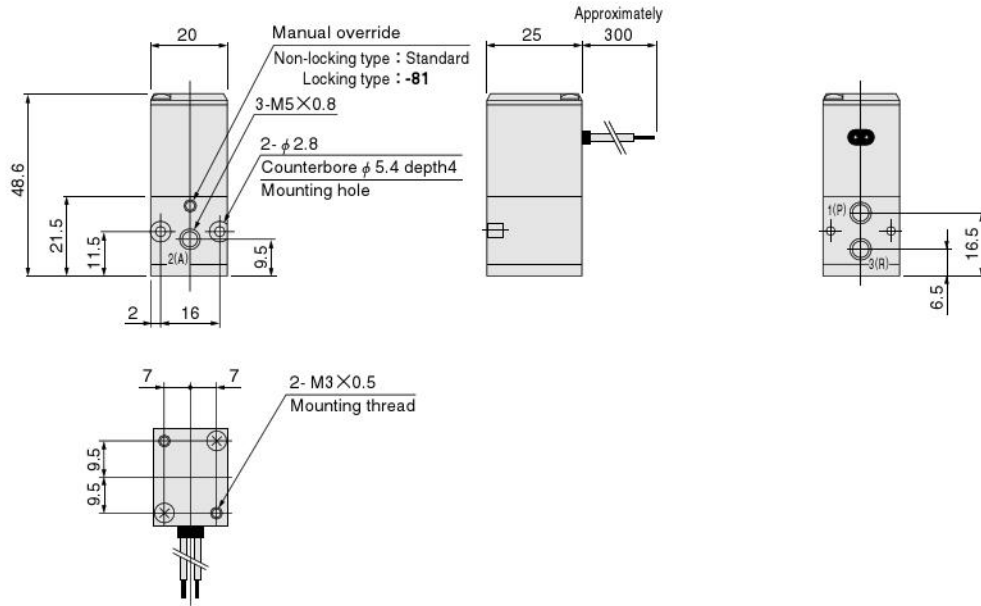

A025E1-25

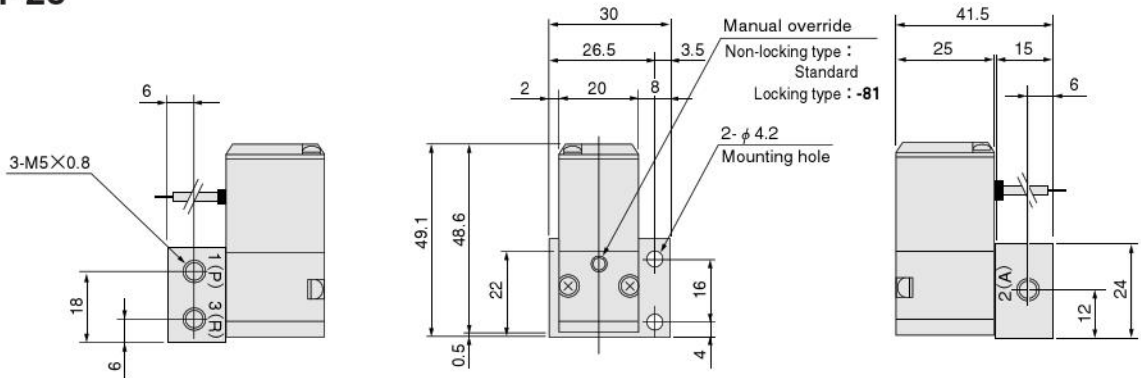

Options

● Mounting base : -21 (Only for 025E1)

● Solenoid with straight connector : -PSL

● Solenoid with L connector : -PLL

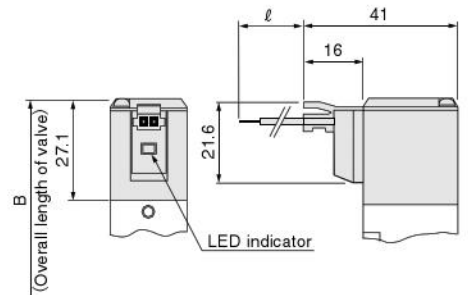
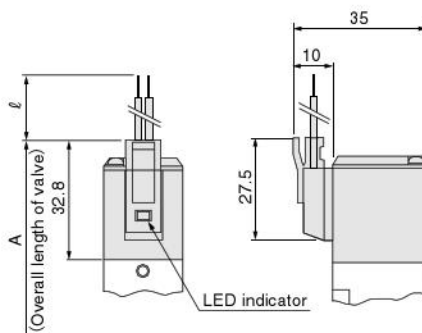
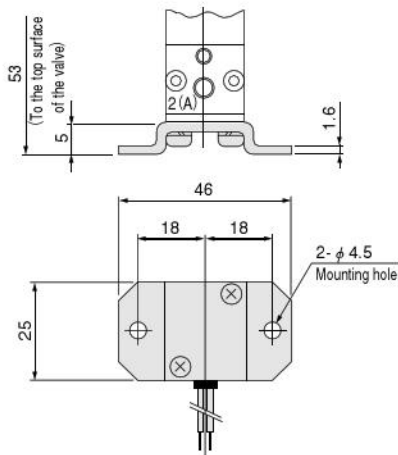

● Muffler : -75

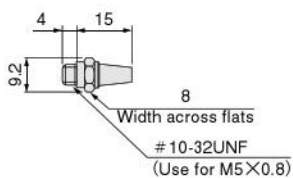

Model	Code	A	B	ℓ (Lead wire length)
025E1		54.3 (To the bottom of the valve)	48.6 (To the bottom of the valve)	Standard: 300
A025E1-25		54.8 (To the bottom of the sub-base)	49.1 (To the bottom of the sub-base)	Optional: -1L: 1000, -3L: 3000

Dimensions of Manifold (mm)

● 025M □ F

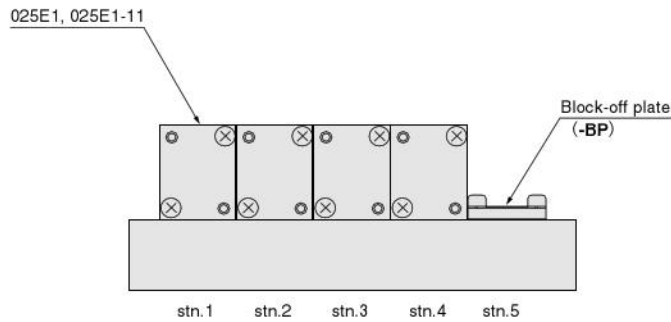
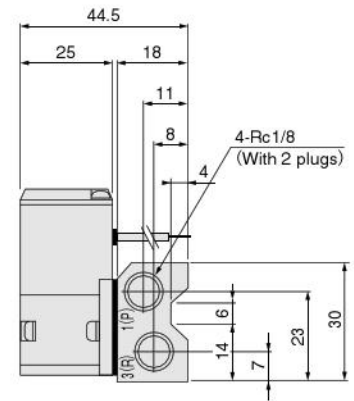
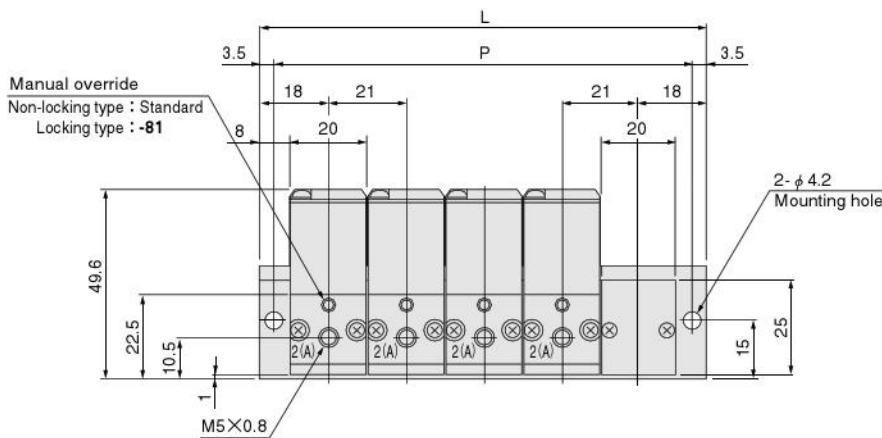

Unit dimensions

Model	P	L
025M2F	50	57
025M3F	71	78
025M4F	92	99
025M5F	113	120
025M6F	134	141
025M7F	155	162
025M8F	176	183
025M9F	197	204
025M10F	218	225

Options

● Solenoid with straight connector : -PSL

● Solenoid with L connector : -PLL

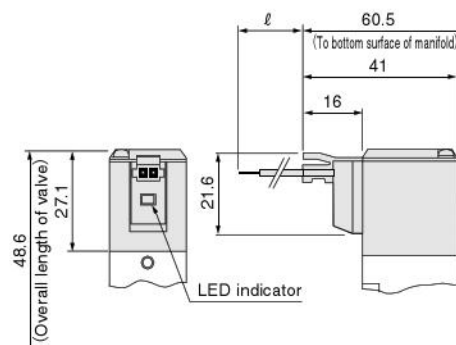
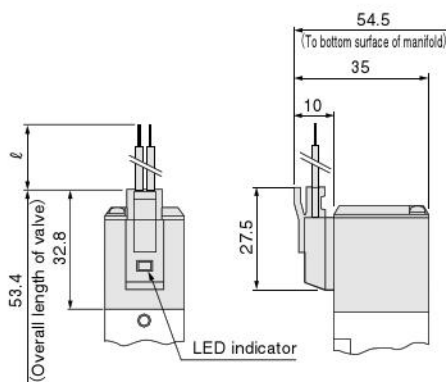

Lead wire length ℓ Standard : 300
 Optional : -1L : 1000, -3L : 3000

Dimensions of Manifold (mm)

● 025M□ A

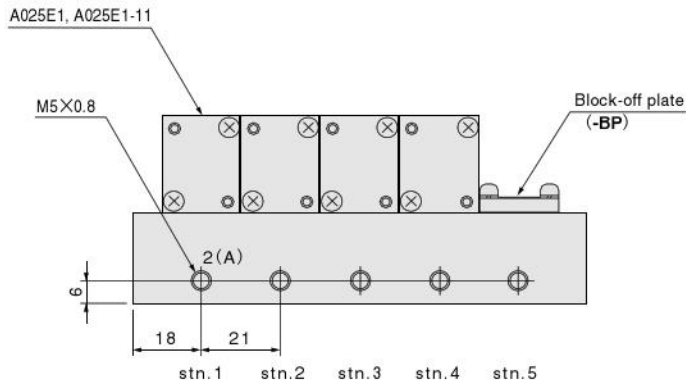
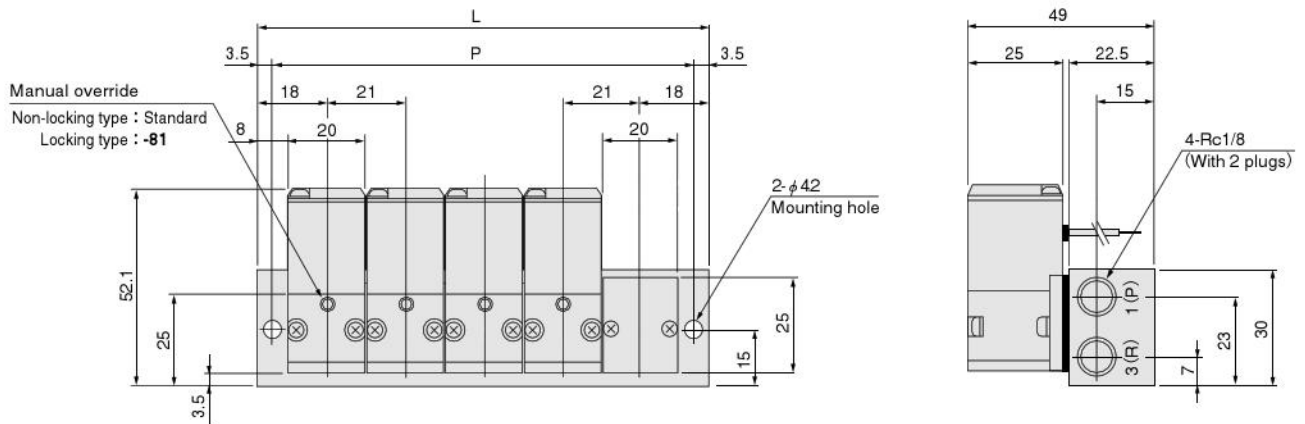

Unit dimensions

Model	P	L
025M2A	50	57
025M3A	71	78
025M4A	92	99
025M5A	113	120
025M6A	134	141
025M7A	155	162
025M8A	176	183
025M9A	197	204
025M10A	218	225

Options

● Solenoid with straight connector : -PSL

● Solenoid with L connector : -PLL

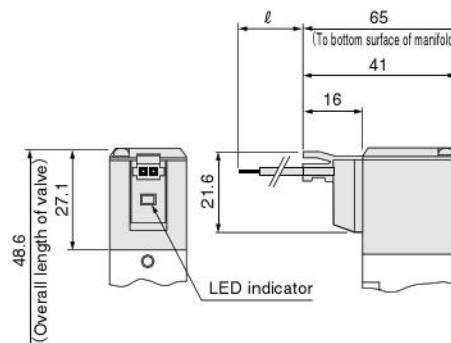
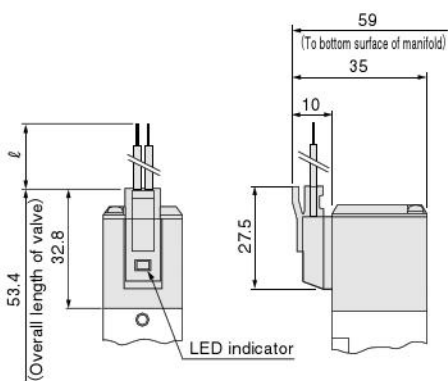

Lead wire length ℓ Standard : 300
 Optional : -1L : 1000, -3L : 3000



Solenoid

Internal circuit

●DC5V, DC12V, DC24V

Standard solenoid (Surge suppression)

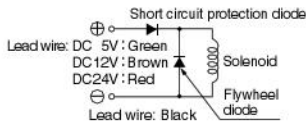

Solenoid with LED indicator (Surge suppression)

Order code : -PSL, -PLL

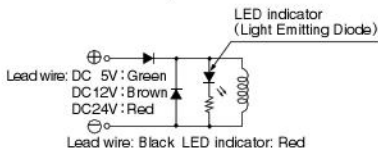

- Cautions:**
1. Do not apply megger between the lead wires.
 2. The DC solenoid will not short circuit even if the wrong polarity is applied, but the valve will not operate.
 3. Leakage current inside the circuit could result in failure of the solenoid valve to return, or in other erratic operation. Always use it within the range of the allowable leakage current. If circuit conditions, etc. cause the leakage current to exceed the maximum allowable leakage current, consult us.
 4. Hold voltage fluctuation to an absolute minimum. In particular, maintain the minimum operating voltage at 90% or more of the rated voltage during solenoid valve operation.



Plug connector

Attaching and removing plug connector

Use fingers to insert the connector into the pin, push it in until the lever claw latches onto the protruded section of the connector housing, and complete the connection.
To remove the connector, squeeze the lever along with the connector, lift the lever claw up from the protruded section of the connector housing, and pull it out.

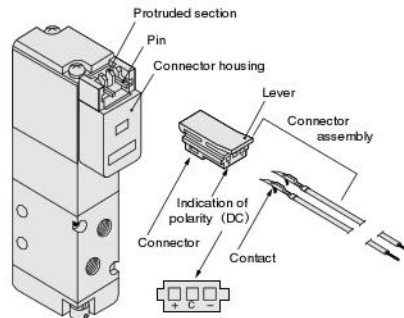

※ Illustration shows the 110 series.

Crimping of connecting lead wire and contact

To crimp lead wires into contacts, strip off 4mm [0.16in.] of the insulation from the end of the lead wire, insert it into the contact, and crimp it. Be sure at this time to avoid catching the insulation on the exposed wire crimping section.

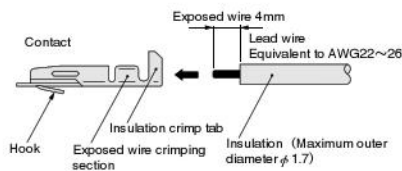

- Cautions:**
1. Do not pull hard on the lead wire.
 2. Always use a dedicated tool for crimping of connecting lead wire and contact.
Contact: Model 702062-2M
Manufactured by Sumiko Tech, Inc.
Crimping tool: Model F1-702062
Manufactured by Sumiko Tech, Inc.

Attaching and removing contact and connector

Insert the contact with lead wire into a plug connector hole until the contact hook latches on and is secured to the plug connector. Confirm that the lead wire cannot be easily pulled out.

To remove it, insert a tool with a fine tip (such as a small screwdriver) into the rectangular hole on the side of the plug connector to push up on the hook, and then pull out the lead wire.

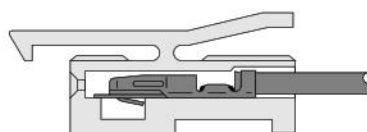

- Cautions:**
1. Do not pull hard on the lead wire. It could result in defective contacts, breaking wires, etc.
 2. If the pin is bent, use a small screwdriver, etc. to gently straighten out the pin, and then complete the connection to the plug connector.



Manual override

Non-locking type

To operate the manual override, press it all the way down. The valve works the same as when in the energized state as long as the manual override is pushed down, and returns to the rest position upon release.

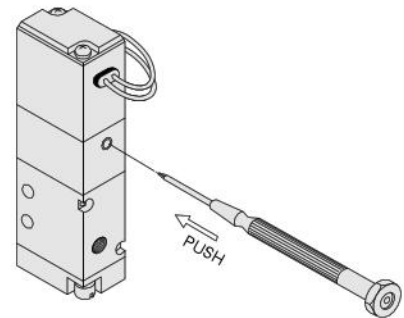

※ Illustration shows the 110 series.

Locking type

To lock the manual override, use a small screwdriver to push down on the manual override all the way and turn it 45 degrees or more. Either turning direction at this time is acceptable. When locked, turning the manual override from the locking position releases a spring on the manual override, returns it to its original position, and releases the lock. When the manual override is not turned, this type acts just like the non-locking type.

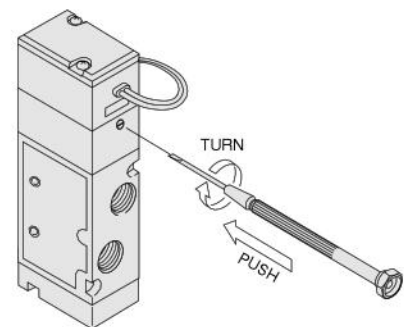

※ Illustration shows the 240 series.

- Cautions:**
1. Always release the lock of the locking type manual override before commencing normal operation.
 2. Do not attempt to operate the manual override with a pin or other object having an extremely fine tip. It could damage the manual override button.
 3. Do not turn the adjusting knob more than the amount needed. It could result in defective operation.