

Micro 3-port Solenoid Valve

World's smallest class

005 Series

Ultra compact 3-port solenoid valves! Valve width **5.9 mm [0.232 in.]**

 Effective area: Standard type, pressure and vacuum type **0.1 mm²**

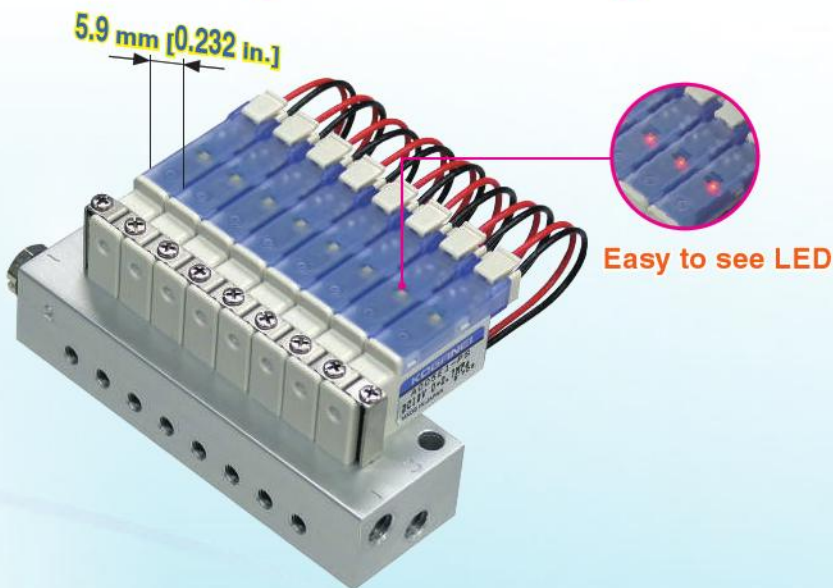
 Large flow rate type **0.2 mm²**
Contributing to size and weight reduction of devices!

New variations

Large flow rate type

 Operating pressure range
0 to 0.3 MPa [0 to 44 psi]

Pressure and vacuum type

 Operating pressure range
-100 kPa to 0.7 MPa
[-29.540 inHg to 102 psi]

- Integrated manifold
- Direct piping block

Installation space is significantly reduced

Split manifold

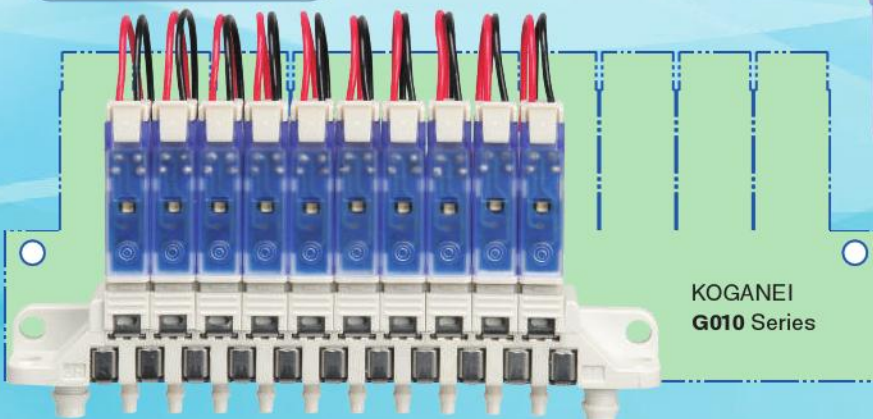
Actual size

Can be mounted in two orientations

Can be mounted in two orientations to match piping direction.

Valves are easy to replace!



Possible to increase or decrease number of valves!

Micro 3-port Solenoid Valve

World's smallest class

005 Series

- Mass of 4.5 g [0.16 oz] (one valve unit)
- Installation space is significantly reduced

Standard type

A type

B type



NEW Large flow rate type

A type

B type



NEW Pressure and vacuum type

A type

B type



	Standard type	NEW Large flow rate type	NEW Pressure and vacuum type
Operating pressure range	0 to 0.7 MPa [0 to 102 psi]	0 to 0.3 MPa [0 to 44 psi]	-100 kPa to 0.7 MPa [-29.540 inHg to 102 psi]
Effective cross-sectional area	0.1 mm ² [Cv value: 0.006]	0.2 mm ² [Cv value: 0.011]	0.1 mm ² [Cv value: 0.006]
Voltage	DC 12 V/DC 24 V		
Housing color	Clear blue	Clear	Clear blue

NEW Direct piping block



For use with
φ 3 [0.118] tube

For use with
φ 3.2 [0.126] tube

NEW Integrated manifold



Split manifold

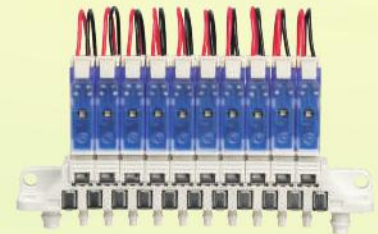

Mountable solenoid valve	NEW Direct piping block	NEW Integrated manifold	Split manifold
Standard type	●	●	●
Large flow rate type	●	●	●
Positive and negative pressure type	●	●	-

Wiring specifications

4 types of wiring specifications

Connector type and pin type are available.



NEW Positive common

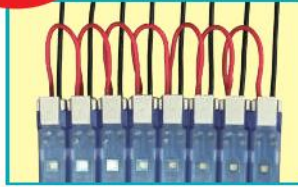

NEW Negative common

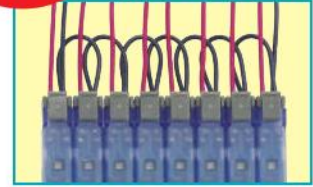

Connector type



Pin type



Direct piping block mounting example

Mounted directly on a device to save space



Direct piping block





Mounting plate and screws



Before selecting and using an appropriate product, please read all the safety precautions carefully to ensure proper product use. The safety precautions described below are intended to help you use the product safely and correctly and to prevent injury to you or other people and damage to property.

Always adhere to ISO4414 (Pneumatic fluid power - General rules and safety requirements for systems and their components), JIS B 8370 (Pneumatic fluid power - General rules relating to systems), and other safety regulations.

The directions are classified according to the degree of potential danger or damage as DANGER, WARNING, CAUTION, and ATTENTION.

 DANGER	Indicates situations that can be clearly predicted as dangerous. Death or serious injury may result if the situation is not avoided. It could also result in property damage or destruction.
 WARNING	Indicates situations that, while not immediately dangerous, could become dangerous. Death or serious injury may result if the situation is not avoided. It could also result in property damage or destruction.
 CAUTION	Indicates situations that, while not immediately dangerous, could become dangerous. Minor or semi-serious injury may result if the situation is not avoided. It could also result in property damage or destruction.
 ATTENTION	While there is no chance of injury, these instructions should be observed for appropriate use of the product.

This product was designed and manufactured for use in general industrial machinery.

- When selecting and handling equipment, the system designer or another person with sufficient knowledge and experience should always read the safety precautions, catalog, instruction manual and other literature before commencing operation. Improper handling is dangerous.
- After reading the instruction manual, catalog, and other documentation, always store them in a location that allows easy availability for reference to users of this product.
- Whenever transferring or lending the product to another person, always attach the catalog, instruction manual, and other information to the product where they are easily visible in order to ensure that the new user can use the product safely and properly.
- The danger, warning, and caution items listed under these safety precautions do not cover all possible contingencies. Read the catalog and instruction manual carefully, and always keep safety first.

 **DANGER**

- Do not use the product for the purposes listed below:
 1. Medical equipment related to maintenance or management of human life or health
 2. Machines or equipment designed for the purpose of moving or transporting people
 3. Critical safety components in mechanical devices
 This product has not been planned or designed for purposes that require high levels of safety. Using the product in any of the ways described above creates the risk of loss of human life.
- Do not use the product in locations with or near dangerous substances such as flammable or ignitable substances. This product is not explosion-proof. Doing so creates the risk of ignition and fire.
- When mounting the product and workpiece, always make sure they are firmly supported and secured in place. Falling, dropping, or abnormal operation of the product creates the risk of personal injury.
- Users of pacemakers or other similar medical devices should maintain a distance of at least 1 m [3.280 ft] from the product. Getting too close to the product creates the risk of malfunction of a pacemaker due to the strong magnet built into the product.
- Never attempt to modify the product in any way. Abnormal operation can lead to injury.
- Never attempt inappropriate disassembly/assembly or repair of the product relating to basic construction, or to its performance or to functions. Doing so creates the risk of injury, electric shock, fire, etc.
- Do not splash water on the product. Spraying water on the product, washing the product, or using the product under water creates the risk of malfunction, leading to injury, electric shock, fire, etc.
- While the product is in operation, avoid touching it with your hands or otherwise approaching too close. Also, do not attempt to make any adjustments to internal or attached mechanisms (by pressing manual buttons, attaching and detaching connectors for wires, adjusting pressure switches, etc., and disconnecting tubes or sealed plugs) while the product is in operation. The actuator may move abruptly, causing injury.

 **WARNING**

- Koganei products can be used under a variety of conditions. To determine compatibility of a specific product with a specific system, the system designer is required to perform adequate evaluation prior to use. The initial performance and safety of the system are up to the designer who has determined compatibility of the product with the system. Safe and reliable system configuration (e.g., failsafe) is required considering the possibility of equipment failure through adequate verification and evaluation of the specifications based on the latest catalog and other technical documents.
- Do not use the product in excess of its specification range. Doing so could cause the product to fail, stop working, and break. Also, significantly reduced service life results.

- Before supplying air or electricity to the product and before starting operation, always conduct a safety check of the area where the equipment is operating. Unintentional supply of air or electricity creates the risk of electric shock or injury due to contact with moving parts.
- Do not touch terminals or switches while the power is turned on. Doing so creates the risk of electric shock and abnormal operation.
- Do not allow the product to be thrown into fire. Doing so creates the risk of the product exploding or the release of toxic gases.
- Do not sit on the product, place your foot on it, or place other objects on it. Doing so creates the risk of injury due to tripping or the product tipping over or falling, resulting in product damage and abnormal, erratic, or runaway operation.
- Before various types of work relating to the product, such as maintenance, inspection, repair, piping (attachment, detachment, and replacement), be sure to totally turn off air supply and make sure to confirm that pressure inside the product and piping connected to the product is zero. In particular, be aware that residual air will still be in the air compressor or the vacuum pump and the air tank. The actuator may move abruptly if residual air pressure remains inside the piping, causing injury.
- Before performing any kind of wiring work, be sure to turn off the power. Failure to do so creates the risk of electric shock.
- Correctly apply the rated voltage to the solenoid. Applying the wrong voltage will make it impossible to obtain the rated function, and create the risk of damage to and burnout of the product.
- Do not allow lead wires and other cords to become damaged. Allowing a cord to become damaged, bent excessively, pulled, rolled up, placed under heavy objects, or squeezed between two objects creates the risk of current leaks or defective continuity that can lead to fire, electric shock, or abnormal operation.
- Do not connect or disconnect connectors while the power is turned on. Also, never apply unnecessary force to connectors. Doing so creates the risk of personal injury, device damage, and electric shock due to abnormal machine operation.
- Always check the catalog and other reference materials for correct product wiring and piping. Improper wiring or piping creates the risk of abnormal operation of the actuator.
- When the product has been idle for over 48 hours or has been in storage, it is possible that the sliding parts may have become stuck leading to operating delays or sudden movements at initial operations. Before these initial operations, always run a test to check that operating performance is normal.
- When the device has not been used for long periods (over 30 days), it is possible that the sliding parts may have become stuck leading to slow operation or sudden movements, eventually resulting in injury. Check for proper operation a minimum of once every 30 days.
- Do not use solenoid valves or the wiring that controls them in locations subject to surges or near strong magnetic fields or power lines through which large electric currents flow. Doing so could result in unintended operation.

Safety Precautions (common to control equipment including air valves)

- When a solenoid valve is turned off, it may generate a surge voltage or an electromagnetic wave that affects the operation of surrounding equipment. Use surge protected solenoids and use countermeasures for electromagnetic waves and surges to electric circuits.
- Do not use the product near the ocean, in direct sunlight, near mercury vapor lamps, or near equipment that generates ozone. Deterioration of rubber parts caused by ozone may reduce performance and functions or stop functions (except for ozone-resistant products).
- Do not use media other than the ones listed in the specification table. Using a medium not listed in the specification table could lead to early shutdown of some functions, a sudden degradation of performance, and a reduced operating life.
- When installing a solenoid valve in the control panel or when the energizing time is long, use countermeasures for heat dissipation so that the ambient temperature of the solenoid valve is always within the specified temperature range. Also, long-term continuous charging can make the coil hot, and the resulting temperature rise could lead to the performance degradation and a reduced operating life of the solenoid valve and adversely affect the equipment nearby. For this reason, if long-term continuous charging is to be performed or if the daily energizing time is longer than the non-energizing time, one possible use is to make the solenoid valve normally open (NO) to shorten the energizing time. For details, contact Koganei.
- After completing wiring work, check to make sure that all connections are correct before turning on the power.
- Do not combine the exhaust system from the air cylinder, etc. with the pilot exhaust system of the solenoid valve, by using piping, etc. Doing so could result in malfunction due to exhaust interference.
- If using the valve in a manifold, make sure that the cylinder does not malfunction and there is no erroneous output from the air blow port due to back pressure when driving the air cylinder and performing air blow work.
- Do not use the product in locations subject to direct sunlight (ultraviolet radiation); in locations subjected to high temperature or humidity; in locations where dust, salt, or iron particles are present; or in locations with media and/or an ambient atmosphere that includes organic solvents, phosphate ester type hydraulic oil, sulfur dioxide gas, chlorine gas, acids, etc. It could lead to early shutdown of some functions, a sudden degradation of performance, and a reduced operating life. For information about materials, refer to "Materials of Major Parts."

CAUTION

- When mounting the product, leave room for adequate working space around it. Failure to do so will make it more difficult to conduct daily inspections or maintenance, which could eventually lead to system shutdown or damage to the product.
- When transporting or mounting a heavy product, firmly support the product using a lift or support, or use multiple people to ensure personal safety.
- Do not bring any magnetic medium or memory within 1 m [3.280 ft] of an energized solenoid valve. Doing so creates the risk of damage to data on the magnetic medium due to magnetism.
- If any leakage current is produced on the control circuit, unintended operation may result depending on the product. Take measures against leakage current on the control circuit so that the allowable leakage current value in the product specifications will not be exceeded.
- Do not use a solenoid valve in locations subject to large electric currents or strong magnetic fields. It could result in erratic operation.
- Oil from the compressor (with the exception of oil-free compressors) may dramatically decrease the product's capabilities or cause the functions to stop. Be sure to remove oil from the air by installing a mist filter preceding the pneumatic equipment.
- If dry air whose dew-point temperature exceeds -20°C [-4°F] is used, the quality of the lubricant used may change. This could lead to a degradation of performance, the shutdown of some functions, and other failures.
- After touching the oil or grease used with the valve, be sure to wash your hands sufficiently. If you smoke a cigarette with a hand with the oil or grease on it, the oil or grease could adhere to the cigarette and burn, producing harmful gas.
- While the product is in operation, avoid touching it with your hands or otherwise approaching too close. Failure to do so creates the risk of burns due to the heat of the coil.

ATTENTION

- Whenever considering use of this product in situations or environments not specifically noted in the catalog or in manuals, or in applications where safety is an important requirement such as in aircraft facilities, combustion equipment, leisure equipment, safety equipment, and other places where human life or assets may be greatly affected, take adequate safety precautions such as allowing plenty of margin for ratings and performance, or fail-safe measures. Contact Koganei regarding use in such applications.

- Mount a silencer (such as a muffler) on the exhaust port. This has the effect of reducing noise during exhaust.
- When handling the product, wear protective gloves, safety glasses, safety shoes, and other protective clothing whenever necessary.
- When the product can no longer be used or is no longer necessary, dispose of it appropriately as industrial waste in accordance with the "Waste Management and Public Cleansing Act" and other regulations and rules of the local government. The oil or grease used with the valve produces hydrofluoric acid (HF), which is corrosive and harmful, when subject to combustion treatment. Dispose of it in an acid-resistant incinerator equipped with a pretreatment facility. If the amount is large, ask a registered waste disposer.
- Pneumatic equipment can exhibit degraded performance and functions over its operating life. Always conduct daily inspections on pneumatic equipment and confirm that all requisite system functions are satisfied to prevent accidents from happening.
- Valves are not completely air leak-free. Designs should take into consideration the capacity and retention time required for pressure (including vacuum) retention within the pressure vessel, etc.
- For inquiries about the product, consult your nearest Koganei sales office or the Overseas Department. The addresses and telephone numbers are shown on the back cover of this catalog.

Other

- Always observe the following items.
 1. When using this product in a pneumatic system, use only genuine Koganei parts or compatible parts (recommended parts). Use only genuine Koganei parts or compatible parts (recommended parts) to do maintenance or repairs. Always observe the prescribed methods and procedures.
 2. Never inappropriately disassemble or modify the product in relation to its basic construction, performance, or functions.

Koganei cannot be held responsible for any problems that occur as a result of these safety precautions not being properly observed.

Warranty and disclaimer

1. **Warranty period**
The warranty period of Koganei products is one year from the date of delivery.
* Some products have a two-year warranty period. For details, contact the nearest Koganei sales office or Overseas Department.
2. **Warranty scope and disclaimer**
 - (1) If a failure attributable to Koganei is found in a product purchased from Koganei or an authorized retailer/dealer during the warranty period, Koganei will repair or replace it free of charge. For some products, a service life, such as the number of operations, may be specified in their warranty periods. For details, contact the nearest Koganei sales office or Overseas Department.
 - (2) The warranty of each Koganei product shall apply to that product alone. Consequently, Koganei shall in no way be responsible for any incidental damage (including costs incurred for the repair and replacement of the product) attributable to any failure of the Koganei product, decrease in function, or decrease in performance.
 - (3) Koganei shall in no way be responsible for any damage induced by any failure of the Koganei product, decrease in function, or decrease in performance or any damage to other devices attributable to the same.
 - (4) Koganei shall in no way be responsible for any damage due to use or storage beyond the range in the product specifications mentioned in the Koganei catalog and the Instruction Manual or due to any acts not mentioned in the mounting, installation, adjustment, maintenance, and other notes.
 - (5) Koganei shall in no way be responsible for any damage caused by any failure of the Koganei product due to any fire not attributable to Koganei, any natural disaster, any act by a third party, the intention or negligence of the customer, etc.

Handling instructions and precautions

Notes on use

- When using a split manifold, hold the valve body and the manifold if external force is applied when connecting or disconnecting connectors or tubes. Otherwise, the manifold may be bent.
- When connecting a connector, hold the connector between fingers and insert the pin until the hook on the lever catches on the protrusion on the housing. To remove a connector, pinch the lever and the connector together, and when the hook on the lever disengages from the protrusion on the housing, and then pull it out.

How to connect tubing

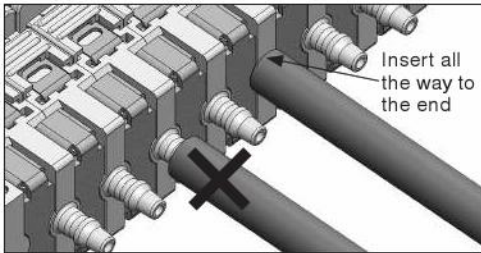

Note: Hold the main body and the manifold when connecting or disconnecting tubes.

- Cut the tube straight across, perpendicular to the axis of the tube. Allow some leeway in the length.
- Slide the tube onto the barb fitting until its end. If it is slid on only part way, air may leak out or the tube may fall off.
- When connecting the tube, be careful not to apply excessive lateral force to the barb fitting.
- When disconnecting the tube, be careful not to apply excessive lateral force to the barb fitting. If you are using a razor knife, be careful not to damage the barb fitting.
- If you are using urethane tubes in high temperatures, the tubes expand as they age, which may lead to air leakage or the tube falling off. We recommend using soft nylon tubes in high temperatures. Avoid using nylon tubes because they require too much force to connect.

Precautions when using the pin type connectors

The pin type connectors are at a pin pitch of 2.54 mm [0.100 in.]. Before using the pin type connectors, carefully check the connection conditions and select connectors that match the pitch of the pins.

How to replace direct piping block valves on the split manifold

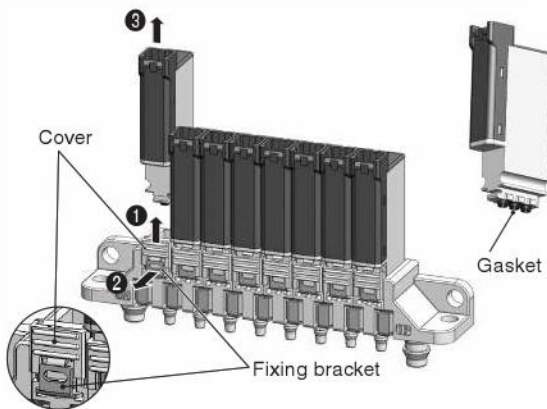

Always turn off the power and the air supplies before starting work.

Removing valves

- Slide the cover in the direction of the arrow (up).
- Use a flathead screwdriver or other thin object to pull out the fixing bracket towards you.
- Pull the valve upward.

Note: If you cannot pull the valve out, the fixing bracket was not pulled out completely in step ②. Do not pull the valve out by force, pull the fixing bracket out again.

Attaching valves

- Confirm that the fixing bracket is pulled out towards you.
- Confirm that the gasket is on the valve, and insert the valve in the base.
- Push in the fixing bracket.
- Slide the cover down until it clicks.

Check to make sure that the fixing bracket is firmly holding the valve before supplying air to the manifold.

How to add and remove valves from the split manifold

Disconnect the tubes and remove the manifold from the equipment, so you can easily handle the job.

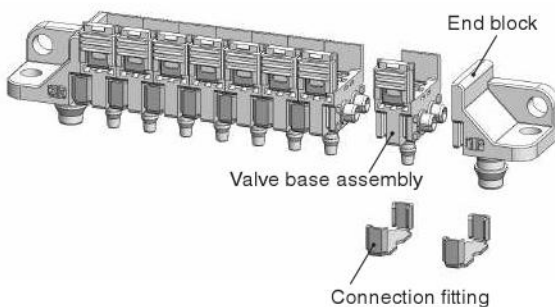

Adding manifolds

Use the manifold up to 20 stations (within one end block set).

- Remove the connection fitting from between the stations where you want to add manifolds.

For example, if you want to add a manifold to the end station, remove the connection fitting from between the end station and the end block.

Note: When removing the fitting, move it forward and backward little by little to remove it. If you pull it off in one pull, you may bend the fitting or damage the base.

- Attach the valve base assembly in the position you want to add it.
Note: Before assembly, confirm there are no foreign debris in the assembly. If dirt or foreign debris are present, it may result in air leakage.
- Lightly press on both sides so there is no gap at the base, then align the connection fitting with the groove in the base, and insert it. Press the connection fitting in until it is even with, or below, the surface of the base.

Removing manifolds

- Remove the connection fittings from both sides of the station that you want to remove.

Note: When removing the fitting, move it forward and backward little by little to remove it. If you pull it off in one pull, you may bend the fitting or damage the base.

- Remove the station you want to remove.

- Connect the bases.

Note: Before connecting the bases, confirm there are no foreign debris in the assembly. If dirt or foreign debris are present, it may result in air leakage.

- Lightly press on both sides so there is no gap at the base, then align the connection fitting with the groove in the base, and insert it. Press the connection fitting in until it is even with, or below, the surface of the base.

Valve functions and piping port positions

	During non-energization	During energization
Positive pressure type		

		During non-energization	During energization
Positive and negative pressure type	If used only in vacuum		
	If used in both positive pressure and vacuum		

Attaching A type valves

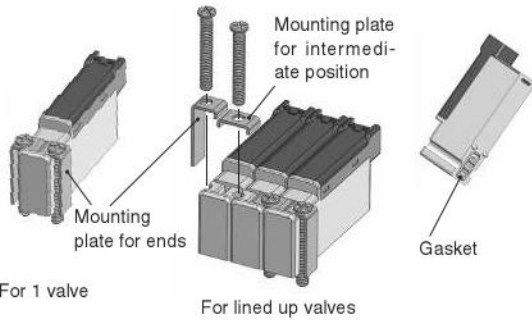

For 1 valve

- ① Put the valve on the base, attach mounting plates for ends.
- ② Tighten the screws provided to a tightening torque of 17.6 N·cm [1.558 in·lbf].
Note: Tighten the screws evenly so the valve does not tilt.

For multiple valves that are lined up

- ① Line up the valves on the base, attach the mounting plates for intermediate positions and for ends.
- ② Tighten the screws provided to a tightening torque of 17.6 N·cm [1.558 in·lbf].
Note: Use the valves in a line at a 6 mm [0.236 in.] pitch. The mounting plates provided (intermediate) are for a 6 mm [0.236 in.] pitch.

Unit dimensions

Number of units	L	P
1	16 [0.630]	26.5 [1.043]
2	22 [0.866]	32.5 [1.280]
3	28 [1.102]	38.5 [1.516]
4	34 [1.339]	44.5 [1.752]
5	40 [1.575]	50.5 [1.988]
6	46 [1.811]	56.5 [2.224]
7	52 [2.047]	62.5 [2.461]
8	58 [2.283]	68.5 [2.697]
9	64 [2.520]	74.5 [2.933]
10	70 [2.756]	80.5 [3.169]
11	76 [2.992]	86.5 [3.406]
12	82 [3.228]	92.5 [3.642]
13	88 [3.465]	98.5 [3.878]
14	94 [3.701]	104.5 [4.114]
15	100 [3.937]	110.5 [4.350]
16	106 [4.173]	116.5 [4.587]
17	112 [4.409]	122.5 [4.823]
18	118 [4.646]	128.5 [5.059]
19	124 [4.882]	134.5 [5.295]
20	130 [5.118]	140.5 [5.531]

■ Cutout dimensions in mounting surface for base piping (recommended)

Image for installation surface for base piping

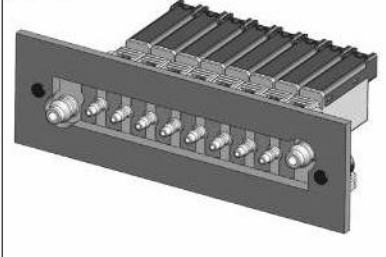

Drill and tap M3 threads on mounting surface for base piping. If you drill a through hole and use a nut, it may interfere with the tubes.

When you are using washers on the mounting screws, use only ISO small round washers (outer diameter $\phi 6$ [0.236]). Tighten the manifold mounting screws to a tightening torque of 49.0 N·cm [4.337 in·lbf].

Regarding dimensions of cutout for base piping

The 10 mm [0.394 in.] dimension in the diagram below is the maximum dimension. If the user wants to set smaller dimensions for the cutout, refer to the outside diameter of the tube connectors below and set the dimensions so there is no interference with the piping.

* There is no problem if the corners shown in the cutout dimensions are rounded during the cutting work.

Air supply/exhaust port tube connector outer diameter: $\phi 7$ [0.276] (for tube U6-□)

Output port tube connector outer diameter: $\phi 5$ [0.197] (for tube U4-□)

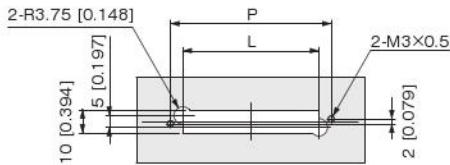

Solenoid

Internal circuit

<Standard and positive and negative pressure type>

- DC 12 V, DC 24 V

LED indicator-attached solenoid with surge protection

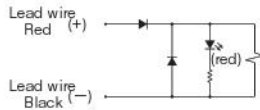

<Large flow rate type>

- DC 12 V, DC 24 V

LED indicator-attached solenoid with surge protection

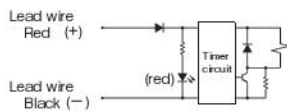

1. Do not conduct a mega test between pins.
2. If any leakage current is in the circuit, malfunction may result, so that the solenoid valve cannot return to normal. Be sure to use the product within the allowable circuit leakage current contained in "Electrical specifications" on page 6. If the leakage current exceeds the allowable value due to circuit conditions, etc., contact the nearest Koganei sales office.
3. The color of the housing is clear blue for the standard type and clear for the large flow rate type.
4. The large flow rate type does not operate if the power voltage is increased gradually. Be sure to apply an appropriate voltage.

Lead wire for common wiring

Number of valves that can be energized simultaneously during common wiring

Voltage	Model	005	
		E1	HE1
DC 12 V		20	20
DC 24 V		20	20

Operation principle of large flow rate type

The large flow rate type adopts a timer circuit such as the one below, so that in the steady state after a certain period of time, the consumption will be about 1/3 of the power consumption at startup, realizing power saving.

- Power waveform

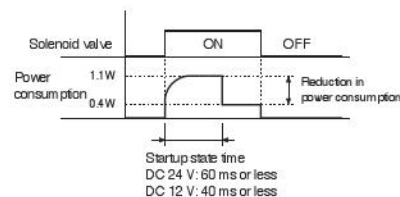

Specifications (standard and large flow rate)

Specifications		A type Base piping		B type Split manifold, direct piping block mount type	
		A005E1-□ (Standard type)	A005HE1-□ (Large flow rate type)	B005E1-□ (Standard type)	B005HE1-□ (Large flow rate type)
Number of positions		2 positions			
Number of ports		3 ports			
Valve function		Normally closed (NC)			
Medium		Air			
Operating method		Direct acting type			
Flow characteristics	Sonic conductance $\text{dm}^3/(\text{s}\cdot\text{bar})$	0.02	0.04	0.02	0.04 (when J3 is mounted: 0.036)
	Effective cross-sectional area ^{Note 1} (Cv value) mm^2 [Cv]	0.1 [0.006]	0.2 [0.011]	0.1 [0.006]	0.2 [0.011] (when J3 is mounted: 0.18 [0.010])
Port size ^{Note 2}		-		Split manifold	1 (P), 3 (R): $\phi 6$ [0.236] (barb fitting), 2 (A): $\phi 3.2$ [0.126], $\phi 4$ [0.157] (barb fitting)
				Direct piping block	$\phi 3$ [0.118], $\phi 3.2$ [0.126] (barb fitting)
Lubrication		Not required			
Operating pressure range		MPa [psi] 0 to 0.7 [0 to 102] ^{Note 3}	0 to 0.3 [0 to 44]	0 to 0.7 [0 to 102] ^{Note 3}	0 to 0.3 [0 to 44]
Proof pressure		MPa [psi] 1.05 [152]	0.45 [65]	1.05 [152]	0.45 [65]
Response time ^{Note 4} (ON/OFF time)		ms 6/6 or less			
Maximum operating frequency		Hz 10	5	10	5
Operating temperature range (atmosphere and medium)		$^{\circ}\text{C}$ [°F] 5 to 50 [41 to 122]			
Shock resistance		m/s^2 [G] 294.2 [30]		Split manifold	294.2 [30] (for 10 stations or fewer), 196.1 [20] (for 11 stations or more)
				Direct piping block	294.2 [30]
Mounting direction		Any			

Note 1: The effective area is a calculated value and is not a measured value.

2: Applicable tubes when using split manifold (outer/inner diameters): $\phi 6$ [0.236]/ $\phi 4$ [0.157], $\phi 4$ [0.157]/ $\phi 2.5$ [0.098], $\phi 3.2$ [0.126]/ $\phi 2$ [0.079]

Applicable tubes when using direct piping block (outer/inner diameters): $\phi 3.2$ [0.126]/ $\phi 2$ [0.079], $\phi 3$ [0.118]/ $\phi 1.5$ [0.059]

3: If a valve of the large flow rate type is mounted together with a valve of the standard type in a manifold, the maximum operating pressure range is 0 to 0.3 MPa [0 to 44 psi]

4: For A005E1 and B005E1, value when air pressure is 0.5 MPa [73 psi]; and for A005HE1 and B005HE1, value when air pressure is 0.3 MPa [44 psi]

Remark: Specification values are based on Koganei test standards.

Remark: Low leakage custom is available for A005E1 and B005E1. Add "-10W" to the end of the order code. Leakage rate of the low leakage custom is 0.1 cc per minute or less at 0.5MPa (73psi) air supply. This leakage rate is a reference value that Koganei factory tests under Koganei test standards before shipment. For more details regarding low leakage custom, consult with Koganei sales office.

Flow characteristics (standard and large flow rate)

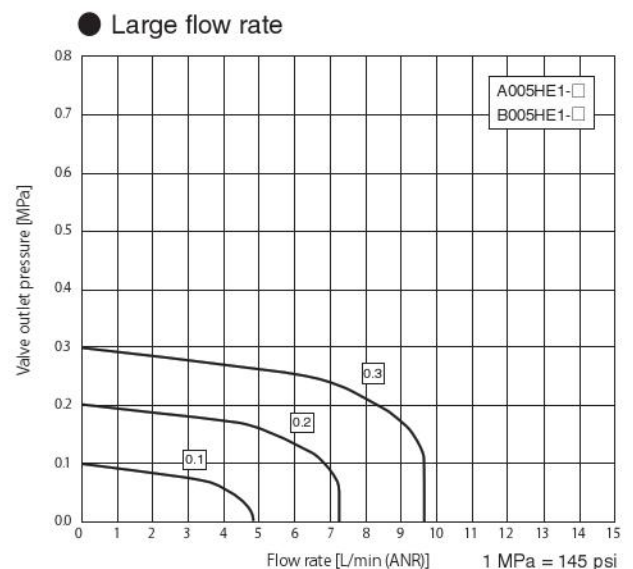
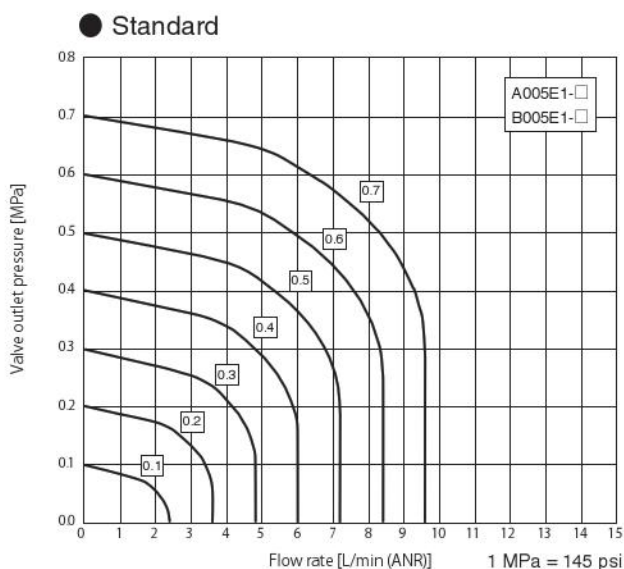

Specifications (Pressure and vacuum type)

Specifications		Model	A type Base piping	B type Direct piping block mount type
			AV005E1- □	BV005E1- □
Number of positions			2 positions	
Number of ports			3 ports	
Valve function			Normally closed (NC)	
Medium			Air	
Operating method			Direct acting type	
Flow characteristics	Sonic conductance $\text{dm}^3/(\text{s}\cdot\text{bar})$		0.02	
	Effective cross-sectional area ^{Note 1} (Cv value) mm^2 [Cv]		0.1 [0.006]	
Port size ^{Note 2}			-	ϕ 3 [0.118], ϕ 3.2 [0.126] (barb fitting)
Lubrication			Not required	
Operating pressure range ^{Note 3} MPa [psi]	1 (P) port		-100 kPa to 0 [-29.540 inHg to 0] 0 to 0.7 [0 to 102]	
	3 (R) port		-100 kPa to 0 [-29.540 inHg to 0]	
Proof pressure MPa [psi]			1.05 [152]	
Response time ^{Note 4} (ON/OFF time)	ms		6/6 or less	
Maximum operating frequency		Hz	10	
Operating temperature range (atmosphere and medium) $^{\circ}\text{C}$ [$^{\circ}\text{F}$]			5 to 50 [41 to 122]	
Shock resistance m/s^2 [G]			294.2 [30]	
Mounting direction			Any	
Air supply port	Positive pressure		1 (P) port	
	Negative pressure		1 (P) port or 3 (P) port	

Note 1: The effective area is a calculated value and is not a measured value.

2: Applicable tubes when using direct piping block (outer/inner diameters): ϕ 3.2 [0.126]/ ϕ 2 [0.079], ϕ 3 [0.118]/ ϕ 1.5 [0.059]

3: If applying vacuum from the 3 (R) port, make sure that the pressure difference from the 1 (P) port is 0.7 MPa [102 psi] or less.

4: Value when air pressure is 0.5 MPa [73 psi].

Remark: Specification values are based on Koganei test standards.

Remark: Low leakage custom is available for AV005E1 and BV005E1. Add "-10W" to the end of the order code. Leakage rate of the low leakage custom is 0.1 cc per minute or less at 0.5MPa (73psi) air supply. This leakage rate is a reference value that Koganei factory tests under Koganei test standards before shipment. For more details regarding low leakage custom, consult with Koganei sales office.

Electrical specifications

Item		Rated voltage	DC 12 V	DC 24 V	
Standard Positive and negative pressure	Applicable voltage range	V	10.8 to 13.2 (12±10%)	21.6 to 26.4 (24±10%)	
	Current value	mA	42	21	
	Power consumption	W	0.5		
	Allowable circuit leakage current	mA	2.0	1.0	
Large flow rate	Applicable voltage range	V	11.4 to 13.2 (12+10% -5%)	21.6 to 26.4 (24±10%)	
	Current value	Startup	mA	92	46
		Steady state	mA	33	17
	Power consumption	Startup	W	1.1	
		Steady state	W	0.4	
	Allowable circuit leakage current	mA	2.0	1.0	
Startup state time (standard time)	ms	40 or less	60 or less		
Type of insulation			B type		
Insulation resistance ^{Note}		MΩ	100 or more		
Color of LED indicator			Red		
Surge protection (standard equipment)			Flywheel diode		

Note: Value at 500 VDC Megger.

Remark: Specification values are based on Koganei test standards.

Internal configuration

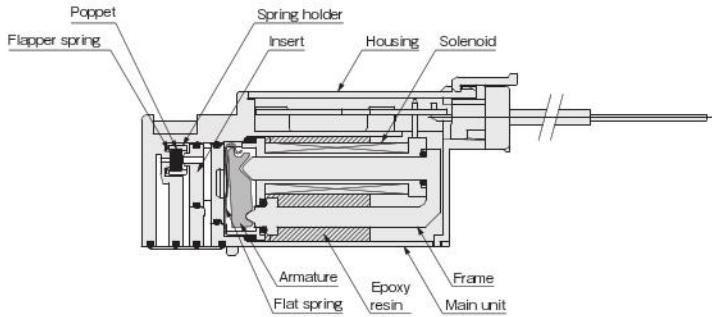

Materials of major parts

	Name	Material
Valve	Main unit	Resin
	Poppet	Synthetic rubber
	Frame	Electromagnetic soft iron
	Armature	Electromagnetic soft iron
	Flat spring	Stainless steel
	Insert	Resin
Split manifold	Base	Resin
	Connection fitting	Stainless steel
	Mounting bracket	Stainless steel
	O-ring	Synthetic rubber
Integrated manifold	Main unit	Aluminum alloy (alumite)

Mass

Mass of one valve unit

Model	Mass	g [oz]
A005E1	4.5 [0.16]	
B005E1		
A005HE1		
B005HE1		
AV005E1		
BV005E1		

* Add the weight of the connector assembly (1.5 g [0.05 oz]) for **-PS**.

* A type mass is without fittings for mounting (mounting plate and screws).

Mass of manifold base

Model	Mass calculation of each manifold unit (n = number of units)	g [oz]
005M□N-J32	$(1.1 [0.04] \times n) + 3 [0.11]$	
005M□N-J4		
005M□A	$(4.3 [0.15] \times n) + 10 [0.35]$	

Calculation example: **005M8N-J32**

stn.1 to stn.8 B005E1-PS DC 24 V

$(4.5 [0.16] + 1.5 [0.05]) \times 8 + (1.1 [0.04] \times 8) + 3 [0.11]$
 $= 59.8 \text{ g [2.11 oz]}$

Mass of direct piping block

Model	Mass	g [oz]
For use with B005E1-J3	0.8 [0.03]	
For use with B005E1-J32		

Order codes

● Valve unit

A type



B type

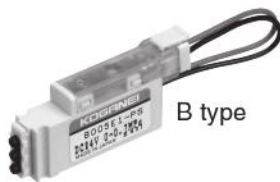

■ Valve form

Blank: For use with a split manifold
 Direct piping block attached
 For use with outer diameter $\phi 3 [0.118]$
 inner diameter $\phi 1.5 [0.059]$ tube



Direct piping block attached
 For use with outer diameter $\phi 3.2 [0.126]$
 inner diameter $\phi 2.0 [0.079]$ tube



■ Wiring specifications

Pin type



S type plug connector
 w/o connector



S type plug connector
 Lead wire 300 mm [11.811 in.]



Basic model	Valve form	Wiring specifications	Voltage
-------------	------------	-----------------------	---------

A type ^{Note 1} Base piping	Standard type	A005E1	Blank -PN -PS	DC 24 V DC 12 V	
	Large flow rate type	A005HE1			
	Pressure and vacuum type	AV005E1			
B type ^{Note 2} Split manifold Direct piping block mount type	Standard type	B005E1			Blank -J3 -J32
	Large flow rate type	B005HE1			
	Pressure and vacuum type	BV005E1			

Note 1: Valve unit cannot be used alone. (Refer to dimensions on page 10.) Each valve is provided with 2 mounting screws, 2 end mounting plates, and 1 intermediate mounting plate for installation.

Note 2: Valve unit cannot be used alone. Mount it on a split manifold or a direct piping block to use it.

Note 3: Do not retain vacuum with the valve. The valve permits air leakage. Thus, retaining vacuum is outside the scope of warranty.

Remark: Low leakage custom is available for A005E1, AV005E1, B005E1 and BV005E1. Add "-10W" to the end of the order code. Leakage rate of the low leakage custom is 0.1 cc per minute or less at 0.5MPa (73psi) air supply. This leakage rate is a reference value that Koganei factory tests under Koganei test standards before shipment. For more details regarding low leakage custom, consult with Koganei sales office.

● Manifold

■ Manifold specifications

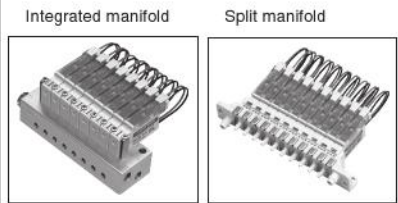

■ Manifold output specifications

For use with outer diameter $\phi 3.2$ [0.126]/inner diameter $\phi 2.0$ [0.079] tube



For use with outer diameter $\phi 4$ [0.157]/inner diameter $\phi 2.5$ [0.098] tube



■ Wiring specifications

Pin type



S type plug connector w/o connector



Plus common wired S type Plug connector lead wire 300 mm [11.811 in.]

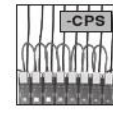

S type plug connector Lead wire 300 mm [11.811 in.]



Minus common wired S type Plug connector lead wire 300 mm [11.811 in.]

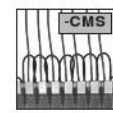

Model	Number of units	Manifold output specifications	Stations	Basic model	Wiring specifications	Voltage
Manifold model			Mounted valve model			

Integrated manifold base piping	005M	1 ⋮ 20	A	-J32 -J4	stn. 1 ⋮ stn. <input type="checkbox"/> Note 1	A005E1 ^{Note 2} A005HE1	Blank -PN -PS -CPS -CMS	DC 24 V DC 12 V
						A005BP (block plate)		
Split manifold	005M	1 ⋮ 20	N	-J32 -J4	stn. 1 ⋮ stn. <input type="checkbox"/> Note 1	AV005E1 ^{Note 3}	Blank -PN -PS -CPS -CMS	DC 24 V DC 12 V
						B005BP (block plate)		

Note 1: Valve mounting location from the left, with the solenoid facing upward and the 2 (A) port side facing the front.
 2: If □005E1 and □005HE1 are also mounted together in a manifold, the maximum operating pressure range is 0 to 0.3 MPa [0 to 44 psi].
 3: A005E1 and A005HE1 cannot be mounted together with AV005E1.
 Remark: Low leakage custom is available for Integrated manifold (A type manifold) with A005E1 and AV005E1. Leakage rate of the low leakage custom per valve station is 0.1 cc per minute or less at 0.5MPa (73psi) air supply. This leakage rate is a reference value that Koganei factory tests under Koganei test standards before shipment. For more details regarding low leakage custom, consult with Koganei sales office.

● Additional parts

Lead wire with connector



005Z-P: Lead wire with connector, length 300 mm [11.811 in.]

Lead wire for common connector

- 005Z-PA :** (Plus common, lead wire length 300 mm [11.811 in.])
- PB : (Plus common, lead wire length 300 mm [11.811 in.])
- PC : (Plus common, lead wire length 300 mm [11.811 in.])
- MA : (Minus common, lead wire length 300 mm [11.811 in.])
- MB : (Minus common, lead wire length 300 mm [11.811 in.])
- MC : (Minus common, lead wire length 300 mm [11.811 in.])

* For details, refer to below.

End block



005Z-E: End block (set of left-right) (with one connection fitting)

Valve base



005Z-VJ32 : Valve base fitting $\phi 3.2$ [0.126 in.]
005Z-VJ4 : Valve base fitting $\phi 4$ [0.157 in.] (with one connection fitting)

Lead wire for common connector

[Wiring examples]

[Lead wire for plus common connector]

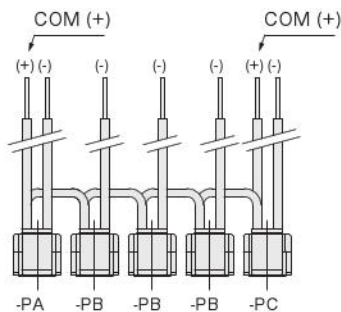

[Lead wire for minus common connector]

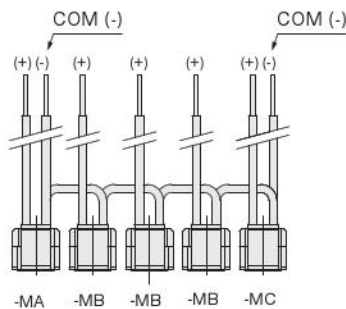

● A type

Gasket



005Z-GS1 : Gasket (A type) (10 pieces a set)

Block plate



005Z-BP1: (A type) (With gasket)

● B type

Gasket



005Z-GS2 : Gasket (B type) (10 pieces a set)

Block plate



005Z-BP2: (B type) (With gasket)

Direct piping block (with mounting bracket and screws)



005Z-BJ32 : Direct piping block, for use with outer diameter $\phi 3.2$ [0.126] inner diameter $\phi 2.0$ [0.079] tube (B type)
005Z-BJ3 : Direct piping block, for use with outer diameter $\phi 3$ [0.118] inner diameter $\phi 1.5$ [0.059] tube (B type)

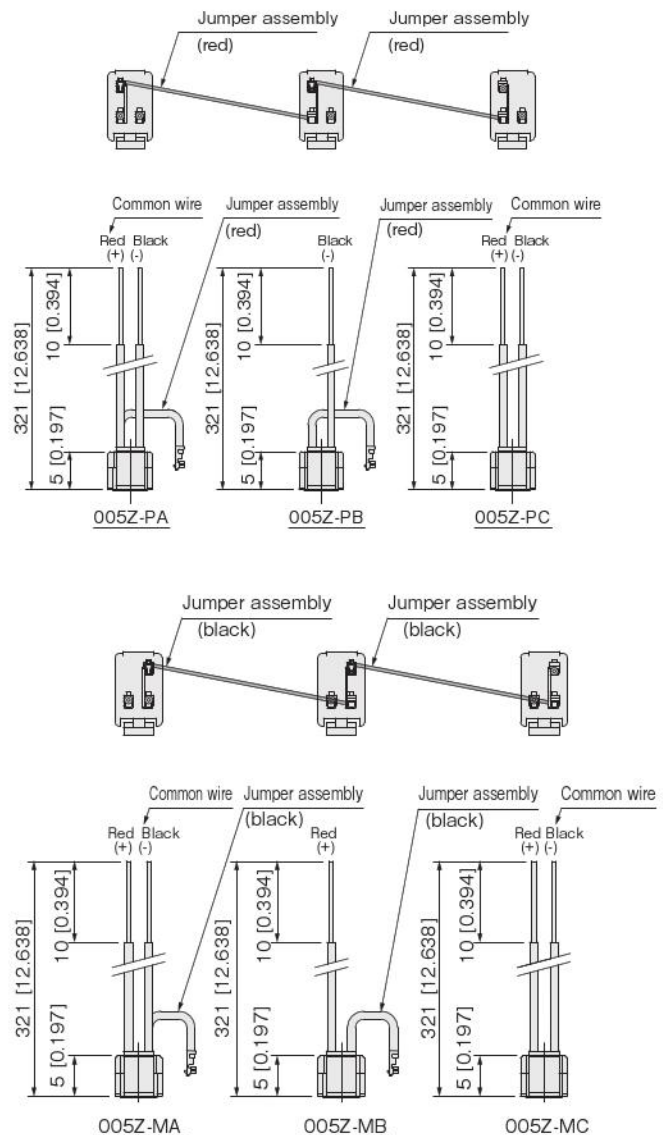

■ One valve unit (A type)

A005E1-PS
AV005E1-PS
A005HE1-PS
 S type plug connector

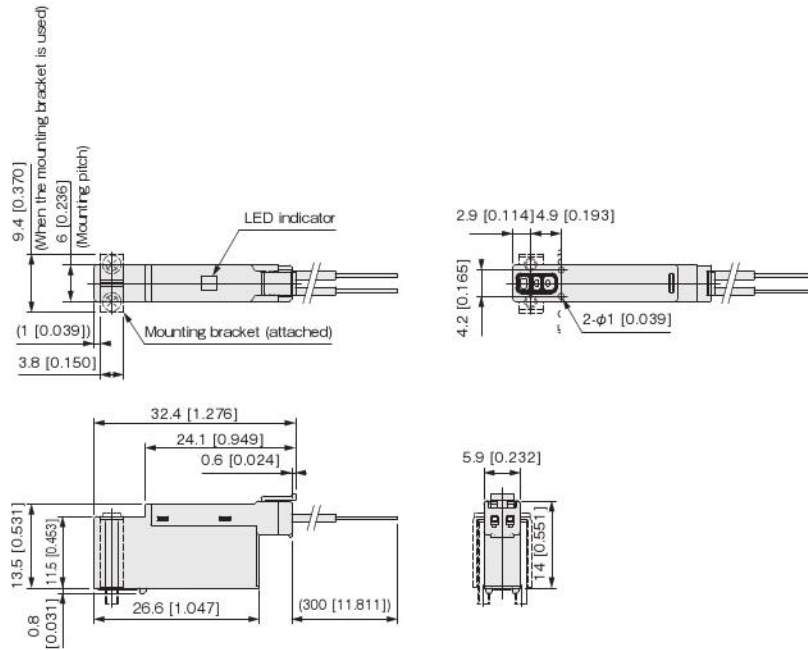

A005E1
AV005E1
A005HE1
 Pin type

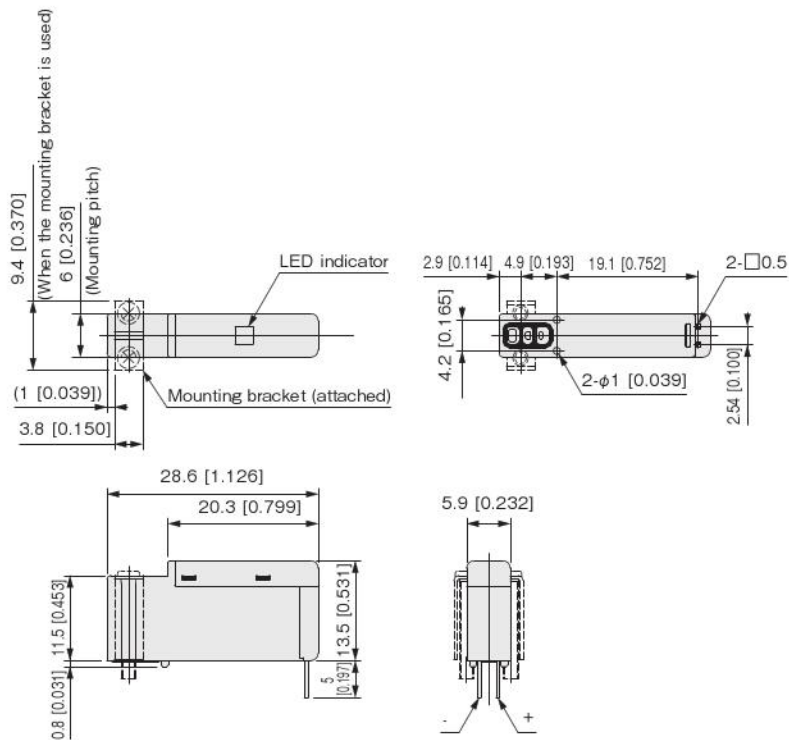

● Gasket groove dimensions

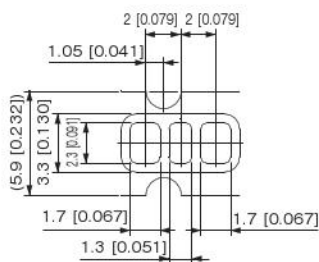

● Base side mounting section reference dimensions (for A type)

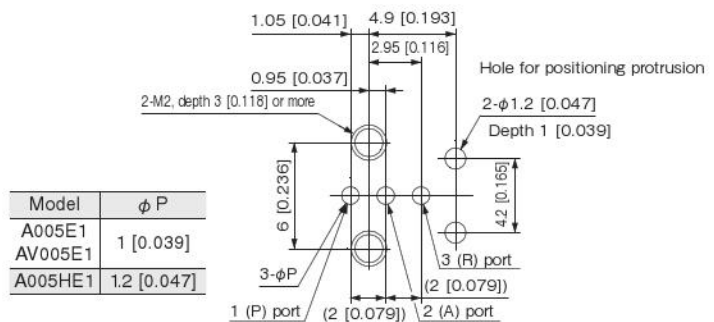

B005E1-J□-PS
BV005E1-J□-PS
B005HE1-J□-PS

S type plug connector with direct piping block

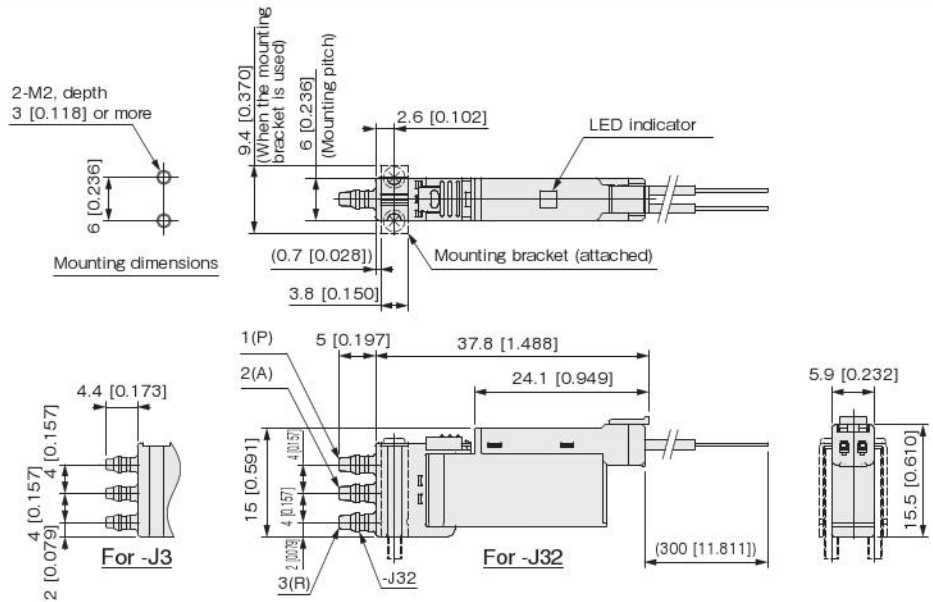

B005E1-J□
BV005E1-J□
B005HE1-J□

Pin type with direct piping block

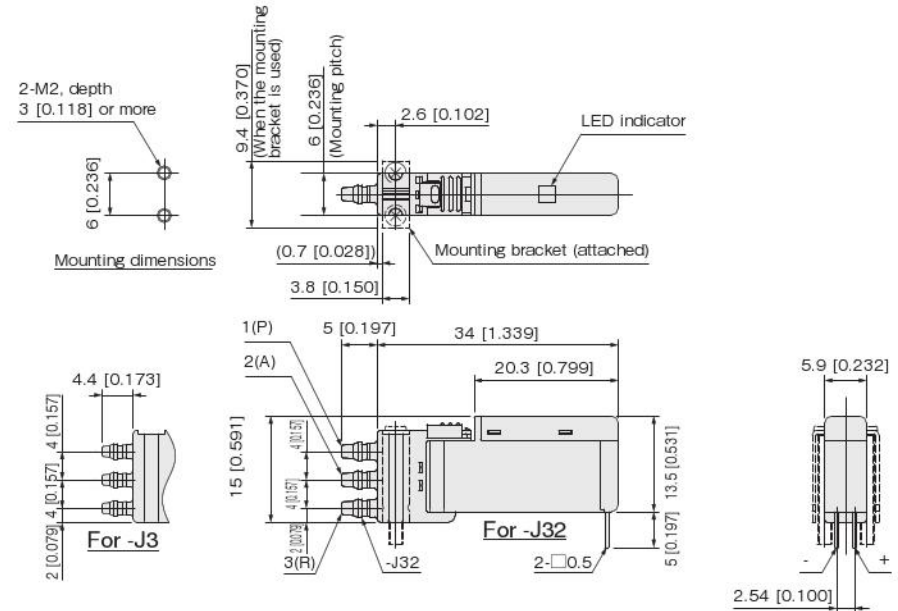

Manifold

005M□A

Integrated manifold base piping type

* Mounted valves are dedicated for the A type.

[Mounting example]
005M10A
 stn.1 to stn.10 A005E1-PS DC 24 V

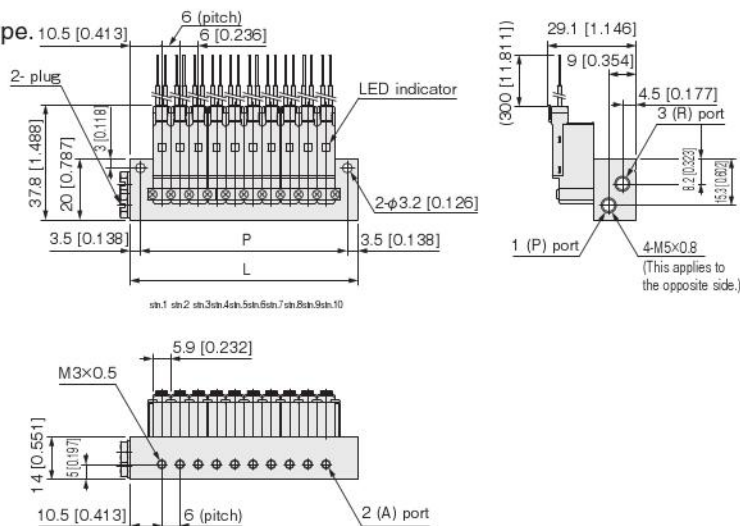

Unit dimensions

Number of units	L	P
1	21.0 [0.827]	14.0 [0.551]
2	27.0 [1.063]	20.0 [0.787]
3	33.0 [1.299]	26.0 [1.024]
4	39.0 [1.535]	32.0 [1.260]
5	45.0 [1.772]	38.0 [1.496]
6	51.0 [2.008]	44.0 [1.732]
7	57.0 [2.244]	50.0 [1.969]
8	63.0 [2.480]	56.0 [2.205]
9	69.0 [2.717]	62.0 [2.441]
10	75.0 [2.953]	68.0 [2.677]
11	81.0 [3.189]	74.0 [2.913]
12	87.0 [3.425]	80.0 [3.150]
13	93.0 [3.661]	86.0 [3.386]
14	99.0 [3.898]	92.0 [3.622]
15	105.0 [4.134]	98.0 [3.858]
16	111.0 [4.370]	104.0 [4.094]
17	117.0 [4.606]	110.0 [4.331]
18	123.0 [4.843]	116.0 [4.567]
19	129.0 [5.079]	122.0 [4.803]
20	135.0 [5.315]	128.0 [5.039]

Manifold

005M□N

S type plug connector split manifold

* Mounted valves are dedicated for the B type.

[Mounting example]

005M8N-J32

stn.1 to stn.8 B005E1-PS DC 24 V

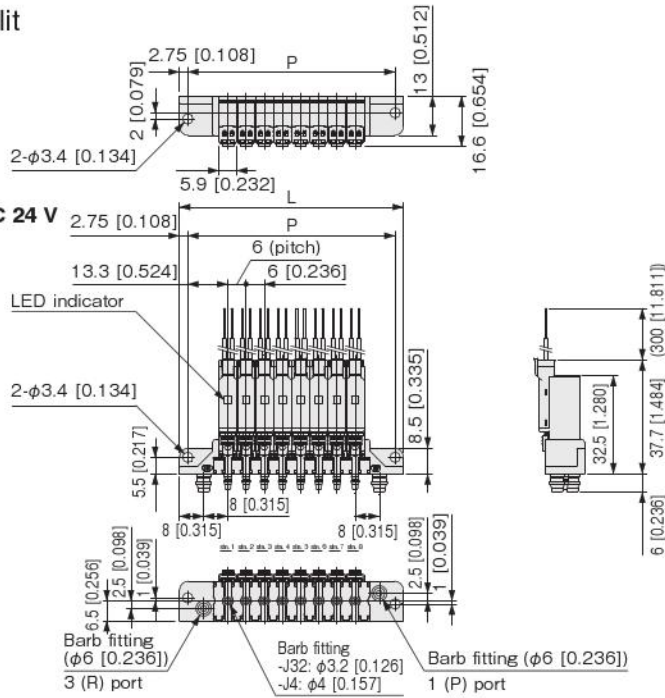

Unit dimensions

Number of units	L	P
1	32.0 [1.260]	26.5 [1.043]
2	38.0 [1.496]	32.5 [1.280]
3	44.0 [1.732]	38.5 [1.516]
4	50.0 [1.969]	44.5 [1.752]
5	56.0 [2.205]	50.5 [1.988]
6	62.0 [2.441]	56.5 [2.224]
7	68.0 [2.677]	62.5 [2.461]
8	74.0 [2.913]	68.5 [2.697]
9	80.0 [3.150]	74.5 [2.933]
10	86.0 [3.386]	80.5 [3.169]
11	92.0 [3.622]	86.5 [3.406]
12	98.0 [3.858]	92.5 [3.642]
13	104.0 [4.094]	98.5 [3.878]
14	110.0 [4.331]	104.5 [4.114]
15	116.0 [4.567]	110.5 [4.350]
16	122.0 [4.803]	116.5 [4.587]
17	128.0 [5.039]	122.5 [4.823]
18	134.0 [5.276]	128.5 [5.059]
19	140.0 [5.512]	134.5 [5.295]
20	146.0 [5.748]	140.5 [5.531]

005M□N

Pin type split manifold

* Mounted valves are dedicated for the B type.

[Mounting example]

005M8N-J4

stn.1 to stn.8 B005E1 DC 24 V

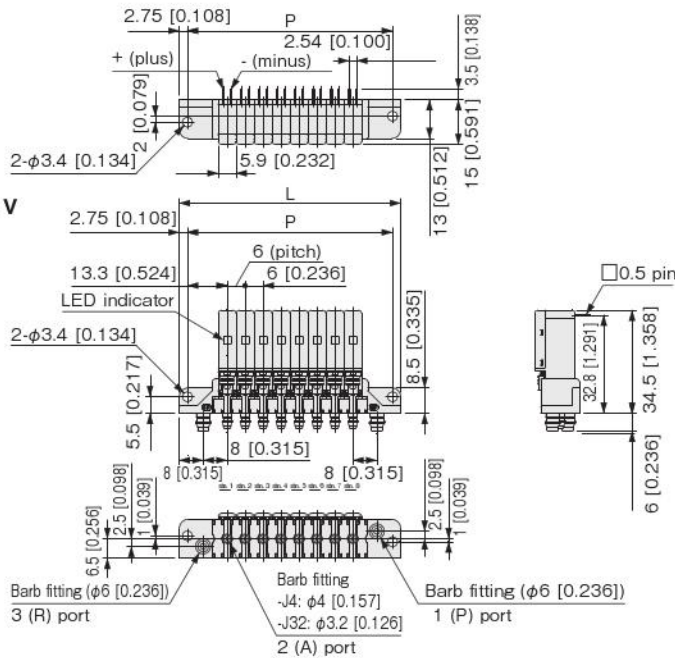

Unit dimensions

Number of units	L	P
1	32.0 [1.260]	26.5 [1.043]
2	38.0 [1.496]	32.5 [1.280]
3	44.0 [1.732]	38.5 [1.516]
4	50.0 [1.969]	44.5 [1.752]
5	56.0 [2.205]	50.5 [1.988]
6	62.0 [2.441]	56.5 [2.224]
7	68.0 [2.677]	62.5 [2.461]
8	74.0 [2.913]	68.5 [2.697]
9	80.0 [3.150]	74.5 [2.933]
10	86.0 [3.386]	80.5 [3.169]
11	92.0 [3.622]	86.5 [3.406]
12	98.0 [3.858]	92.5 [3.642]
13	104.0 [4.094]	98.5 [3.878]
14	110.0 [4.331]	104.5 [4.114]
15	116.0 [4.567]	110.5 [4.350]
16	122.0 [4.803]	116.5 [4.587]
17	128.0 [5.039]	122.5 [4.823]
18	134.0 [5.276]	128.5 [5.059]
19	140.0 [5.512]	134.5 [5.295]
20	146.0 [5.748]	140.5 [5.531]

Limited Warranty

KOGANEI CORP. warrants its products to be free from defects in material and workmanship subject to the following provisions.

Warranty Period The warranty period is 180 days from the date of delivery.

Koganei Responsibility If a defect in material or workmanship is found during the warranty period, KOGANEI CORP. will replace any part proved defective under normal use free of charge and will provide the service necessary to replace such a part.

Limitations ● This warranty is in lieu of all other warranties, expressed or implied, and is limited to the original cost of the product and shall not include any transportation fee, the cost of installation or any liability for direct, indirect or consequential damage or delay resulting from the defects.

● KOGANEI CORP. shall in no way be liable or responsible for injuries or damage to persons or property arising out of the use or operation of the manufacturer's product.

● This warranty shall be void if the engineered safety devices are removed, made inoperative or not periodically checked for proper functioning.

● Any operation beyond the rated capacity, any improper use or application, or any improper installation of the product, or any substitution upon it with parts not furnished or approved by KOGANEI CORP., shall void this warranty.

● This warranty covers only such items supplied by KOGANEI CORP. The products of other manufacturers are covered only by such warranties made by those original manufacturers, even though such items may have been included as the components.

The specifications are subject to change without notice.

URL <http://www.koganei.co.jp>

E-mail: overseas@koganei.co.jp



KOGANEI CORPORATION

OVERSEAS DEPARTMENT

3-11-28, Midori-cho, Koganei City, Tokyo 184-8533, Japan
Tel: 81-42-383-7271 Fax: 81-42-383-7276

KOGANEI INTERNATIONAL AMERICA, INC.

48860 Milmont Drive, suite 108C, Fremont, California 94538
Tel : 1-510-744-1626 Fax : 1-510-744-1676

SHANGHAI KOGANEI INTERNATIONAL TRADING CORPORATION

Room 2606-2607, Tongda Venture Building No.1, Lane 600, Tianshan Road,
Shanghai, 200051, China
Tel: 86-21-6145-7313 Fax: 86-21-6145-7323

TAIWAN KOGANEI TRADING CO., LTD.

Rm. 2, 13F, No88, Sec. 2, Zhongxiao E. Rd., Zhongzheng Dist., Taipei City 100,
Taiwan (ROC)
Tel: 886-2-2393-2717 Fax: 886-2-2393-2719

KOGANEI KOREA CO., LTD.

6F-601, Tower Bldg., 1005, Yeongde0-dong, Giheung-gu, Yongin-si, Gyeonggi-do,
446-908, Korea
Tel: 82-31-246-0414 Fax: 82-31-246-0415

KOGANEI (THAILAND) CO., LTD.

555 Rasa Tower 1, 12th Floor, Unit 1202 and 1207, Phaholyothin Road, Chatuchak, Bangkok 10900 Thailand
Tel: 66-2-937-4250 Fax: 66-2-937-4254

KOGANEI AUTOMATION (MALAYSIA) SDN.BHD.

Suite 29-2, Level 29, Menara 1MK, No.1, Jalan Kiara, Mont Kiara
50480, Kuala Lumpur, Malaysia
Tel: 60-12-537-7086

KOGANEI ASIA PTE. LTD.

69 Ubi Road 1, #05-18 Oxley Bizhub, Singapore 408731
Tel: 65-6293-4512 Fax: 65-6293-4513